

Review Article

EFFICACY OF LIVE ATTENUATED DENGUE VACCINES: CYD-TDV; TDV (TAK-003) AND TV003/TV005

Yoseph Jeffry Hertanto¹, Bernadette Dian Novita² 

¹Medical Internship Program, Faculty of Medicine, Universitas Katolik Widya Mandala, Surabaya, Indonesia

²Department of Pharmacology and Therapy, Faculty of Medicine, Universitas Katolik Widya Mandala, Surabaya, Indonesia

ABSTRACT

Dengue fever is the most common tropical disease, but there still remains no specific therapy that can overcome it. Special attention needs to be paid to this disease, because there were large increases in incidence in the last decade. As an effective preventive strategy, finding a new vaccine for dengue fever with higher potentiation and efficacy is highly necessary to stop dengue transmission especially in the endemic area. Vaccine triggers an immune response, so that it can create a robust immune response when infected. Nowadays, there is only one licensed dengue vaccine that is CYD-TDV (Dengvaxia). However, this vaccine still has many weaknesses, namely its dependency on the serostatus of the recipient. There are also other dengue vaccines that are in ongoing clinical testing and have promising results, TDV (TAK-003) and TV003/TV005. These three vaccines are live attenuated vaccines with various results. This review discussed differences in the efficacy of CYD-TDV against the other TAK-003 and TV003/TV005; considering the known and unknown various factors.

Keywords: Live attenuated dengue vaccines; CYD-TDV; TAK-003; TV003/TV005; tropical disease

ABSTRAK

Demam dengue merupakan penyakit tropis yang sering terjadi, namun masih belum ada terapi spesifik untuk mengatasinya. Perhatian khusus perlu diberikan pada penyakit ini, karena terdapat peningkatan insiden yang signifikan pada dekade terakhir. Penemuan vaksin baru demam dengue dengan potensi dan efektivitas yang diperlukan merupakan salah satu strategi pencegahan efektif yang diperlukan untuk memutus mata rantai penularan demam berdarah/ dengue terutama di daerah endemik. Vaksin memicu respons imun, sehingga dapat menciptakan respons imun yang kuat saat terinfeksi. Saat ini, hanya ada satu vaksin dengue berlisensi yaitu CYD-TDV (Dengvaxia). Vaksin ini memiliki kelemahan, yaitu efikasi tergantung pada serostatus penerima. Terdapat vaksin dengue lain yang sedang menjalani uji klinis dan memiliki hasil yang menjanjikan, TDV (TAK-003) dan TV003/TV005. Ketiga vaksin ini merupakan vaksin hidup yang dilemahkan dengan hasil yang beragam. Ulasan ini membahas perbedaan kemanjuran CYD-TDV terhadap TAK-003 dan TV003/TV005 lainnya; mempertimbangkan berbagai faktor yang diketahui dan tidak diketahui.

Kata Kunci: Live attenuated dengue vaccines; CYD-TDV; TAK-003; TV003/TV005; penyakit tropis

Correspondence: Bernadette Dian Novita, Department of Pharmacology and Therapy, Faculty of Medicine, Universitas Katolik Widya Mandala, Surabaya 60112, Indonesia. Email: novita@ukwms.ac.id

pISSN:2355-8393 • eISSN: 2599-056x • doi: 10.20473/fmi.v57i4.21741

• Fol Med Indones. 2021;57:365-371 • Submitted 15 Jan 2021 • Revised 25 Jul 2021 • Accepted 11 Aug 2021

• Open access under CC-BY-NC-SA license • Available at <https://e-journal.unair.ac.id/FMI/>

INTRODUCTION

Dengue is an infectious disease caused by dengue virus (DENV) which is transmitted through the bite of *Aedes* mosquitoes (especially *Aedes aegypti*), and it is one of the most common tropical diseases in the world. DENV is a single chain positive RNA virus consisting of four serotypes (DENV 1, DENV 2, DENV 3, and DENV 4), belongs to the Flaviviridae family, Flavivirus genus

(including Zika, yellow fever, Japanese Encephalitis) (Wang et al. 2020). Someone who has been infected with DENV will have lifetime immunity against the same DENV serotype. It means that a person during his life can be infected four times. Dengue can be found in the tropical and subtropical countries of the world, especially in endemic countries with 10% of fever episodes that are caused by dengue (Wilder-Smith 2020). The incidence of dengue has increased in the last

decade. A recent study discovered that the infection incidence is 390 million per year, of which 96 million experienced clinical symptoms (in varying degrees). The incidence rate was 8-fold compared to the last two decades (from 505.430 cases in 2000 to 4.2 million by 2019) (World Health Organization 2014). Another study estimates that 3,900 million people are at risk to have dengue infection. This rapid increase is due to several factors, such as the increasing population, increasing urbanization and migration including international travel, global climate change, and difficulty to overcome vectors effectively and sustainably (Pinheiro-Michelsen et al. 2020, Murray et al. 2013).

Nowadays, there remains no specific treatment to cure dengue. The number of individuals who are at risk of getting dengue makes this disease highly important to be treated. The most effective strategy to overcome dengue is preventive, and is currently done by doing vector control. Yet, the control of this vector is sufficiently complex, because it is multidisciplinary and multi sector that can consume a lot of money and work (Da Silveira et al. 2019), so that the development of effective and safe dengue vaccine is an urgent necessity. The ideal dengue vaccine is a vaccine given in single doses that can protect against all four DENV serotypes, providing long-term protection, and having no side effects. The recognized dengue vaccine has related problems to the immune response and cross-reactive T-cell responses implicated in a dysfunctional immune response that may contribute to more severe cases of secondary DENV infection. However, more recent works point to the value of more robust T-cell immunity in reducing the risk of developing severe manifestations of DENV infection (Collins & Metz 2017).

MATERIALS AND METHODS

This study was a systematic literature review conducted by collecting a number of literatures related to the problem and research objectives. In this study, we searched journal articles about dengue vaccines and its characteristics, efficacy, safety, and clinical trials status by reading it to make a theoretical summary, so that a complete review about dengue vaccines was obtained.

RESULTS

There were several vaccines that had entered the clinical trial phase, namely TV003/TV005, TDV/DENVax (TAK-003), PIV, V180, DIME100, TVDV, and TLAV Prime. From these vaccines, there was only one vaccine that had been approved and licensed to be consumed in endemic areas, namely CYD-TDV (Dengvaxia) (Deng

et al. 2020). In addition, there were two vaccines that had undertaken phase III clinical trials. Many studies had examined the efficacy of dengue vaccines.

In this review, we discussed vaccines that had been approved, namely CYD-TDV and vaccines in phase III clinical trials, TDV (TAK-003), and TV003/TV005 (LATV/Butantan-DV/TetraVax-DV), because many studies in the clinical trials showed promising results, where the live attenuated vaccine provided the advantage to stimulate and neutralize antibodies in humans than other types of vaccines, such as recombinant subunit vaccines (triggering a balanced immune response, problems of endotoxin contamination, and improper protein folding), and DNA vaccines (low immunogenicity), and vaccines with relatively low production prices that generally only required a single dose to provide protection, and had shown satisfactory results for other diseases caused by flaviviruses (Deng et al. 2020, Kallas et al. 2020).

DISCUSSION

CYD-TDV (Dengvaxia)

CYD-TDV (Chimeric Yellow fever 17D Virus-Tetavalent Dengue Vaccine) is a live attenuated, recombinant tetavalent vaccine developed by Sanofi Pasteur and has been licensed in endemic countries in Asia and Latin America under the trade name Dengvaxia. This vaccine has been through phase I-III clinical trials involving more than 45,000 participants from 16 countries before licensed (Pinheiro-Michelsen et al. 2020). This vaccine is a quadrivalent combination of four monovalent chimeric attenuated viruses that comprise the prM (pre-membrane) and E (envelop) sequence of each DENV serotype grafted on to the nonstructural protein backbone of YF17D (yellow fever virus vaccine strain). The live attenuated vaccine, CYD-TDV works as an agent of RNA replication, so that it stimulates the response of the humoral and induces controlled stimulation of dendritic cells and other immune responses. The strains used in CYD-TDV are genetically and phenotypically stable, non-hepatotropic and less neurovirulent than the strains used in YFV 17D (Wang et al. 2020, Collins & Metz 2017). The structure of this vaccine can be seen in Figure 1. This vaccine is given 3 times with a length sequence of 6 months, because in previous studies, seroconversion in vaccine recipients with 3 doses could reach up to 100% compared to 2 doses which only reached 92% (Pinheiro-Michelsen et al. 2020).

Table 1. Differences of three vaccines in this review

	CYD-TDV	TAK-003	TV003/TV005
Phase	IV (licensed)	III	III
Age	9 - 45 years old (SAGE)	Phase III Studies: 2-60 years olds	Phase III Studies: 12 -70 years olds
Dosage	3 dosage, 6 months apart	2 dosage, 3 months apart	Single dose
Administration	Subcutaneous	Subcutaneous	Subcutaneous
Duration Protection	Up to 5 years in seropositive	Over 3 years	At least 1 years*
Reaction	Seroconversion with neutralizing antibodies	Seroconversion with neutralizing antibodies and inducing cellular immune responses	Seroconversion with neutralizing antibodies and inducing cellular immune responses
Serostatus	Must be given to seropositive persons	Regardless serostatus	Regardless serostatus
Safety	No serious side effects, must be given to seropositive persons	No serious side effects	No serious side effects, most side effect are Rash
Overall Efficacy	± 59.2%	± 80.6%	Tetravalent neutralizing response 76%
Efficacy to Seropositive	± 76%	± 82.2%	No data*
Efficacy to Seronegative	± 39%	± 74.9%	No data*
Efficacy for DENV1	± 54.7%	± 73.7%	No data*
Efficacy for DENV2	± 43%	± 97.7%	No data*
Efficacy for DENV3	± 71.8%	± 62.6%	No data*
Efficacy for DENV4	± 76.9%	± 63.3%	No data*

*need more data from future studies

There are several factors that can affect the efficacy of this vaccine, including age, virus serotype and vaccine recipient serostatus (Hadinegoro et al. 2015). In its development, in phase IIb clinical trials in Thailand and phase III clinical trials in Asia and Latin America, this vaccine showed protection against DENV3 and also DENV4, moderate protection against DENV1, but it did not provide good protection for DENV2 with the level of efficacy protection against each serotype was 54.7% (DENV1), 43.0% (DENV2), 71.8% (DENV3), and 76.9% (DENV4). Overall, the level of efficacy of protection against all DENV within 1 year after the administration of the third dose vaccine was 59.2% (Collins & Metz 2017).

The serostatus of vaccine recipients also affects the efficacy of this vaccine, whereby vaccine recipients who have previously been infected with one of the DENV serotypes have better results (more effectively) than those that have never been infected. This indicates that CYD-TDV is better suited to improve and expand the existing immunity rather than provoking or incurring protection against all DENV serotypes in individuals who have never been infected previously (Collins & Metz 2017). This can occur, because the vaccine may play a role in stimulating the existing immune memory.

In a case-cohort study on the effect of serostatus on vaccine safety and efficacy concluded that CYD-TDV protected against severe dengue and hospitalized for dengue in individuals who had been previously infected

(seropositive), whereas inversely to those who had never been infected previously (seronegative) (Sridhar et al. 2018). With the use of CYD-TDV, seronegative individuals aged 9-16 years had a hazard ratio of 1.41 (95% confidence interval [CI] 0.74-2.68) for hospital admission due to dengue, while seropositive had a hazard ratio of 0.21 (95% CI 0.14 - 0.31). In the case of severe dengue exposure, the hazard ratio for individuals with seronegative is 2.44 (95% CI 0.47 - 12.56), while that in seropositive is 0.16 (95% CI 0.07 - 0.37). This study also examined individuals aged 2 - 8 years, and those with seronegative had a hazard ratio of 1.95 (95% CI 1.19 - 3.19) for hospital admission due to dengue, while seropositive had a hazard ratio of 0.5 (95% CI 0.33 - 0.77).

In the case of severe dengue exposure, the hazard ratio for individuals with seronegative was 3.31 (95% CI 0.87 - 12.54), while that in seropositive was 0.58 (95% CI 0.26 - 1.30) (Sridhar et al. 2018). From this study, the administration of these vaccines will be more effective in individuals with age above 9 years and also has seropositive status. Other studies also showed that the risk of hospitalization due to dengue and risk of severe dengue increases in the 3 - 4 years after the first dose due to the protection given by the vaccine that had been reduced or due to the disappearance of neutralizing antibodies and leaving only enhancing antibodies (Arredondo-García et al. 2018, Plotkin 2020).

Related to serostatus, overall efficacy of the vaccine to prevent symptomatic dengue in individuals with seronegative was 39% (individuals over 9 years old) and 19% (individuals aged 2-8 years). Efficacy in individuals with seropositive status was 76% (individuals over 9 years) and 60% (aged 2-8 years) (Sridhar et al. 2018, World Health Organization 2018). In regard to age, a study in Asia showed a higher efficacy in children over 9 years of age from children aged 2 - 5 years (Da Silveira 2019). Similarly, another study stated that the efficacy of the vaccine to prevent symptomatic dengue in children over 9 years was 65.6% compared to those under 9 years (44.6%) (Hadinegoro et al. 2015).

The duration of protection that CYD-TDV could provide was at least 5 years for those with seropositivity (Wang et al. 2020, Sridhar et al. 2018). This vaccine is also relatively safe compared to other vaccines given to children (e.g., diphtheria and tetanus vaccines) because it has fewer side effects. However, as explained above, the use of this vaccine in those with seronegative can increase the risk of being hospitalized and suffering from severe dengue. This is probably because the CYD-TDV vaccine is partially mimics primary infection, so that it plays a role in antibody-dependent enhancement (ADE) for a second infection (Sridhar et al. 2018, Swaminathan & Khanna 2019, Harenberg et al. 2016). Giving children under 9 years old also increases the risk of hospital admission and suffering severe dengue. However, the mechanism is still unclear (Deng et al. 2020, Collins et al. 2017).

In the updated recommendation from SAGE (Strategic Advisory Group of Experts) in 2018, World Health Organization (2018) informed that this CYD-TDV vaccine was given only to 9-45 years old with seropositive status (thus pre-vaccine screening is necessary), because it could increase the risk of hospital admission and severe dengue exposure in seronegative individuals. In addition, as of 1st May 2019, the Food and Drug Administration (FDA) indicated this vaccine was only for individuals 9-16 years with a history of previous dengue infection that had been proven by laboratory results in medical records.

TDV (TAK-003)

Similar to the manufacture of CYD-TDV, TAK-003 replaces YF17D with DENV2 PDK-53 (laboratory-derived attenuated virus). DENV2 PDK-53 was chosen, because a study showed that this strain even used in recombine remains replicate uniformly and also relatively safe (Pinheiro-Michelsen et al. 2020). Also, because it used the DENV2 strain, there was a nonstructural (NS) DENV2 protein in this vaccine

(Wilder-Smith 2020). To get immunity against all serotypes, prM and E proteins from DENV1, DENV3, and DENV4 have been replaced to DENV2 PDK-53 genetic backbone to get vaccine strains for each serotype (TDV-1, TDV-2, TDV-3, and DENV4 TDV-4). TAK-003 was a combination of TDV 1-4 developed by Takeda Vaccines (Biswal et al. 2019). The structure of this vaccine can be seen in Figure 2.

Similar to CYD-TDV as a live attenuated vaccine, TAK-003 acts as an agent of RNA replication that can stimulate humoral and cellular immune systems. In addition, this TAK-003 vaccine generates a CD8 + pool of NS1, NS3, and NS5 reactive T cells capable of producing IFN- γ , TNF- α , and to a lesser extent IL-2 upon ex vivo restimulation which may arise due to the presence of NS proteins causing cross-reactive T-cell mediated responses to broad protection against dengue (Wang et al. 2020, Wilder-Smith 2020, Waickman et al. 2019, Prompetchara et al. 2020, Sáez-llorens et al. 2017). This vaccine showed seroconversion rates of 84 - 100% for DENV1, 96 - 100% for DENV2, 83 - 100% for DENV3, and 33 - 77% for DENV4 (Pinheiro-Michelsen et al. 2020).

Other studies also proved that the overall seroconversion (all serotypes) for this vaccine was 88% in those with seronegative and 97% in those with seropositive (Macias et al. 2020). TAK-003 vaccine is given twice with an interval of three months, because giving a second dose could increase immunity to DENV3 and DENV4 especially in those with seronegative baseline (Sáez-llorens et al. 2017, Sáez-llorens et al. 2017). This vaccine is currently still in phase III clinical trials in Asia and Latin America.

A study by Shibadas et al in phase III clinical trials with subjects aged 4-16 years, found that the efficacy of this vaccine to prevent virologically confirmed dengue (which was confirmed through RT-PCR testing) was 80.6% (95% CI 73.8 - 85.6) (Biswal et al. 2019). Another study in phase II clinical trials also reported the relative risk (Rr) for the occurrence of virologically confirmed dengue in TAK-003 recipient individuals was 0.35 (CI 0.19 - 0.65) (Tricou et al. 2020). Regarding the type of DENV serotype, in contrast to CYD-TDV, this vaccine showed a high efficacy against DENV2 (efficacy 97.7%) with a different efficacy for DENV1 (73.7%), DENV3 (62.6%), and DENV4 (63.2%) (Biswal et al 2019).

In addition to children aged 4 - 16 years in a phase I clinical trial, Chukiat et al (in Sirivichayakul et al. 2015) showed that this vaccine could induce immunity against all four DENV serotypes in individuals aged 1.5 - 45 years both with seropositive and seronegative.

Regarding the serostatus of vaccine recipient individuals, there were differences in efficacy with seropositive and seronegative people, but this difference was not as great as CYD -TDV. The efficacy of this vaccine against individuals with seronegative was 74.9% and against seropositive was 82.2% (Biswal et al. 2019). In the same study, the efficacy of this vaccine to prevent hospital admission due to dengue was 95.4% (95% CI 88.4 - 98.2%), where the efficacy in seronegative individuals was 97.2% and in seropositive individuals 94.4%. This is interesting to note, because the efficacy in seronegative sufferers is higher than that of seropositive, so that this vaccine may be suitable for use with seronegative compared to CYD -TDV.

Two studies with phase III clinical trials within 48 months, had shown that this vaccine provided a long-term antibody persistence with evidence of high levels of antibodies above the baseline (Tricou et al. 2020, Biswal et al. 2020). Other studies had also shown that this vaccine could provide protection for at least 3 years after the first dose as evidenced by the presence of antibody titers on peripheral blood tests. Even after 3 years, seropositivity rates for DENV1, 2, 3 were still high (88 - 97%) and moderate for DENV4 (56%) (Sirivichayakul et al. 2020).

Regarding the safety of using TAK- 003, some studies had shown that this vaccine could be well tolerated and classified as safe to use as proven by the incidence of side effects that are relatively small in the vaccine and control group. From the study with a total of 20, 078 subjects (13, 380 vaccine recipients and 6,687 controls) who experienced serious side effects were 1 person from the vaccine group and 4 people from the control group (2 people had hypersensitivity, 2 were diagnosed with dengue, and 1 was diagnosed with dengue hemorrhagic fever) (Biswal et al. 2019).

All previous data may undergo a change later, because the vaccine is still in the clinical trial phase. Further studies were necessary to evaluate the final results of this vaccine. However, this vaccine remains a high efficacy to prevent dengue and also hospitalization due to dengue, including in children under 9 years and regardless of serostatus.

TV003 / TV005

The second vaccine that is currently in phase III clinical trial phase is TV003 / TV005 which is also a live attenuated vaccine. This vaccine was developed by the Laboratory of Infectious Disease (LID) of the National Institute of Allergy and Infectious Diseases (NIAID), which is also licensed by manufacturers from Brazil (Butantan Institute), Vietnam (Vabiotech), India (Panacea Biotech and Serum Institute of India), and global licensed by Merck & Co (Whitehead 2016) This vaccine is a live attenuated tetravalent vaccine (LATV) which is a combination of four attenuated recombinant monovalent DENV: rDENV1Δ30, rDENV2/4Δ30, rDENV3Δ30/31, dan rDENV4Δ30 (Pinheiro-Michelsen et al. 2020, Deng et al. 2020, Swaminathan & Khanna 2019). Figure 1C provides the structure of this vaccine.

This attenuated virus was created using recombinant DNA technology by removing nucleotides from 3' untranslated regions (3'UTR) from each strain of DENV. This region was chosen as a target, because it played an important role in RNA replication (Pinheiro-Michelsen et al. 2020). Of the four components, one component is chimeric strain (rDENV2 / 4Δ30) which is made by replacing prM and E protein from the rDENV4Δ30 backbone with prM, and E protein from DENV2.

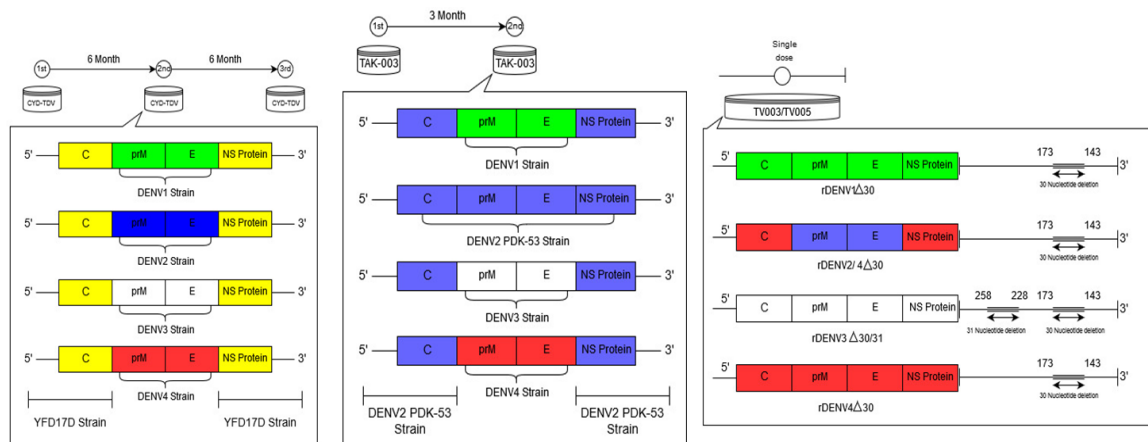

Figure 1. Structure of: (a) CYD -TDV (Dengvaxia); (b) TAK -003; (c) TV003 / TV005
 Source: (Pinheiro-Michelsen et al. 2020, Collins & Metz 2017, World Health Organization, 2018)

Because this vaccine is made with three components of the dengue virus mutation, i.e. rDENV1Δ30, rDENV3Δ30/31, and rDENV4Δ30, this vaccine also contains the same non-structural protein as the nonstructural protein of "wild" DENV 1, DENV 3, and DENV 4, so that this vaccine also stimulates cellular immune responses (T cells) besides producing neutralizing antibodies (Pinheiro-Michelsen et al. 2020, Whitehead 2016, Durbin & Gubler 2019).

The difference from TV003 and TV005 is the doses of one component (rDENV2/ 4Δ30), on TV003 each component has a dose of 103 PFU (Plaque Forming Unit), while on TV005 the dose of rDENV2/ 4Δ30 increased to 104 PFU (Pinheiro-Michelsen et al. 2020, Whitehead 2016). This vaccine is a single dose, because in the study, a second dose after 6 or 12 months did not trigger an increase in antibody titers and cellular response to any DENV serotype significantly, which proved that a single dose alone was sufficient to prevent virus replication and protect from disease with sufficient neutralizing antibody responses (Kallas et al 2020, Whitehead et al 2020, Kirkpatrick et al 2015)

.Efficacy data of this vaccine is still not available. A study by Whitehead (2016) showed that tetravalent immune responses to TV003 were 87% in those who had been exposed to flavivirus before, and 66% in those who had never been exposed. The frequency of seroconversion of each serotype also varies, namely 89%, 95%, 97%, 100% for DENV 1, 2, 3 and 4 in those who had been exposed to flaviviruses. Those who had never been exposed were 95%, 67%, 98%, 100% for DENV 1, 2, 3, and 4 (Whitehead et al 2017). A recent study showed that the frequency of tetravalent neutralizing antibodies was 76% (Kallas et al 2020). In addition, there were other studies comparing TV003 and TV005 resulting in tetravalent immune responses with TV003 were 74% and increased to 90% with TV005. Besides, the specific immune response for DENV2 also increased from 76% (TV003) to 97% (TV005), whereas for other serotypes, it was not much different (Kirkpatrick et al. 2015).

Regarding safety, the use of the TV003/ TV005 vaccine was classified as safe, because previous studies did not find serious side effects. Most of the side effects that appeared and were also significantly different from the control group were rash (66% - 76% of total vaccine recipients), where these effects could disappear without treatment intervention. The rashes are generally mild, and only a few are classified as moderate due to pruritus. Besides, the side effects that arise were not also influenced by the initial serostatus

of the vaccine recipient (Kallas et al 2020, Whitehead et al 2017, Kirkpatrick et al 2016).

Based on previous studies, the use of TV003 / TV005 is classified as safe, tolerable, and can provide protection against dengue in the recipient both seropositive and seronegative. We are now waiting for further research in phase III clinical trials to see the extent of efficacy from this vaccine, so that it can be accepted in the future community.

CONCLUSION

To date, only one vaccine has been approved and licensed (CYD-TDV). However, the vaccine is still less effective and efficient in preventing dengue, so that its use should be reconsidered or restricted. Many other promising vaccines such as TAK-003 and TV003/ TV005 are still in the clinical trial phase, so that they still cannot be fully recognized. Yet from various research reports, this vaccine showed satisfactory results in performance. In general, all of these dengue vaccines show a good outcome to prevent dengue infections.

It is expected that the vaccine with one-time administration, independent of serostatus, and can be used at any age range (especially children), and reachable by various levels of society can be developed immediately. More studies on these vaccines can be done in the near future. In addition, further study about dengue vaccine efficacy in younger ages is necessary.

REFERENCES

- Arredondo-García JL, Hadinegoro SR, Reynales H, et al (2018). Four-year safety follow-up of the tetravalent dengue vaccine efficacy randomized controlled trials in Asia and Latin America. *Clin Microbiol Infect* 24, 755-63.
- Biswal S, Borja-tabora C, Vargas LM, et al (2020). Efficacy of a tetravalent dengue vaccine in healthy children aged 4 – 16 years: A randomised, placebo-controlled, phase 3 trial. *Lancet* 395, 1423-1433.
- Biswal S, Reynales H, Saez-Llorens X, et al (2019). Efficacy of a tetravalent dengue vaccine in healthy children and adolescents. *N Engl J Med* 381, 2009-2019.
- Collins MH, Metz SW (2017). Progress and works in progress: Update on flavivirus vaccine Development. *Clin Ther* 39, 1519-36.
- Collins MH, Metz SW, Carolina N (2017). Progress and works in progress: Update on flavivirus vaccine development. *Clin Ther* 39, 1519-36.

- Da Silveira LTC, Tura B, Santos M (2019). Systematic review of dengue vaccine efficacy. *BMC Infect Dis* 19, 1-8.
- Deng S, Yang X, Wei Y, et al (2020). A review on dengue vaccine development. *Vaccines* 8, 1-13.
- Durbin AP, Gubler DJ (2019). What is the prospect of a safe and effective dengue vaccine for travellers? *J Travel Med* 26, 1-2.
- Hadinegoro SR, Arredondo-García JL, Capeding MR, et al (2015). Efficacy and long-term safety of a dengue vaccine in regions of endemic disease. *N Engl J Med* 373, 1195-206.
- Harenberg A, Montfort AD, Jantet-blaudez F (2016). Cytokine profile of children hospitalized with virologically-confirmed dengue during two phase III vaccine efficacy trials. *PLoS Negl Trop Dis* 10, 1-17.
- Kallas EG, Precioso AR, Palacios R, et al (2020). Safety and immunogenicity of the tetravalent, live-attenuated dengue vaccine Butantan-DV in adults in Brazil: A two-step, double-blind, randomised placebo-controlled phase 2 trial. *Lancet Infect Dis* 20, 839-850.
- Kirkpatrick BD, Durbin AP, Pierce KK, et al (2015). Robust and balanced immune responses to all 4 dengue virus serotypes following administration of a single dose of a live attenuated tetravalent dengue vaccine to healthy, flavivirus-naïve adults. *J Infect Dis* 212, 702-710.
- Kirkpatrick BD, Whitehead SS, Pierce KK, et al (2016). The live attenuated dengue vaccine TV003 elicits complete protection against dengue in a human challenge model. *Sci Transl Med* 8, 330-336.
- Macias A, Ruiz-Palacios G, Ramos-Castaneda J (2020). Combine dengue vaccines to optimize effectiveness. *Vaccine* 38, 4801-4804.
- Murray NEA, Quam MB, Wilder-Smith A (2013). Epidemiology of dengue: Past, present and future prospects. *Clin Epidemiol* 5, 299-309.
- Pinheiro-Michelsen JR, Souza RdSO, Santana IVR, et al (2020). Anti-dengue Vaccines: From development to clinical trials. *Front Immunol* 11, 1-18.
- Plotkin SA (2020). Dengue vaccine - A double-edged sword. *J Pediatric Infect Dis Soc* 9, 107-109.
- Prompetchara E, Ketloy C, Thomas SJ, et al (2020). Dengue vaccine: Global development update. *Asian Pacific J Allergy Immunol* 38, 178-185.
- Sáez-llorens X, Tricou V, Yu D, et al (2017). Immunogenicity and safety of one versus two doses of tetravalent dengue vaccine in healthy children aged 2 – 17 years in Asia and Latin America: 18-month interim data from a phase 2, randomised, placebo-controlled study. *Lancet Infect Dis* 2099, 1-9.
- Sáez-llorens X, Tricou V, Yu D, et al (2017). Safety and immunogenicity of one versus two doses of Takeda's tetravalent dengue vaccine in children in Asia and Latin America: Interim results from a phase 2, randomised, placebo-controlled study. *Lancet Infect Dis* 3099, 1-11.
- Sirivichayakul C, Barranco-santana EA, Esquilin-rivera I, et al (2015). Safety and immunogenicity of a tetravalent dengue vaccine (TDV) in healthy children and adults in endemic regions: A randomized, placebo-controlled Phase 2 study. *J Infect Dis* 213, 1562-1572.
- Sirivichayakul C, Barranco-santana EA, Rivera IE, et al (2020). Long-term safety and immunogenicity of a tetravalent dengue vaccine candidate in children and adults: a randomized, placebo-controlled, phase 2 study. *J Infect Dis* 406, 1-8.
- Sridhar S, Luedtke A, Langevin E, et al (2018). Effect of dengue serostatus on dengue vaccine safety and efficacy. *N Engl J Med* 379, 327-40.
- Swaminathan S, Khanna N (2019). Dengue vaccine development: Global and Indian scenarios. *Int J Infect Dis* 84, 80-86.
- Tricou V, Sáez-Llorens X, Yu D, et al (2020). Safety and immunogenicity of a tetravalent dengue vaccine in children aged 2–17 years: A randomised, placebo-controlled, phase 2 trial. *Lancet* 395, 1434-1443.
- Waickman AT, Friberg H, Gargulak M, et al (2019). Assessing the diversity and stability of cellular immunity generated in response to the candidate live-attenuated dengue virus vaccine TAK-003. *Front Immunol* 10, 1-13.
- Wang W, Nayim A, Chang MR, et al (2020). Dengue hemorrhagic fever: A systemic literature review of current perspectives on pathogenesis, prevention and control. *J Microbiol Immunol Infect* 53, 963-978.
- Whitehead SS (2016). Development of TV003 / TV005, a single dose, highly immunogenic live attenuated dengue vaccine; what makes this vaccine different from the Sanofi- Pasteur CYD TM vaccine? *Expert Rev Vaccines* 15, 509-517.
- Whitehead SS, Durbin AP, Pierce KK, et al (2017). In a randomized trial, the live attenuated tetravalent dengue vaccine TV003 is well-tolerated and highly immunogenic in subjects with flavivirus exposure prior to vaccination. *PLoS Negl Trop Dis* 11, 1-19.
- Wilder-Smith A (2020). Dengue vaccine development: Status and future. *Bundesgesundheitsblatt Gesundheitsforsch Gesundheitsschutz* 63, 40-4.
- World Health Organization (2014). Dengue and Severe Dengue. WHO Fact Sheet. Available from www.who.int. Accessed August 9, 2020.
- World Health Organization (2018). Revised SAGE Recommendation on Use of Dengue Vaccine. Available from: <http://www.who.int>. Accessed August 20, 2020.