

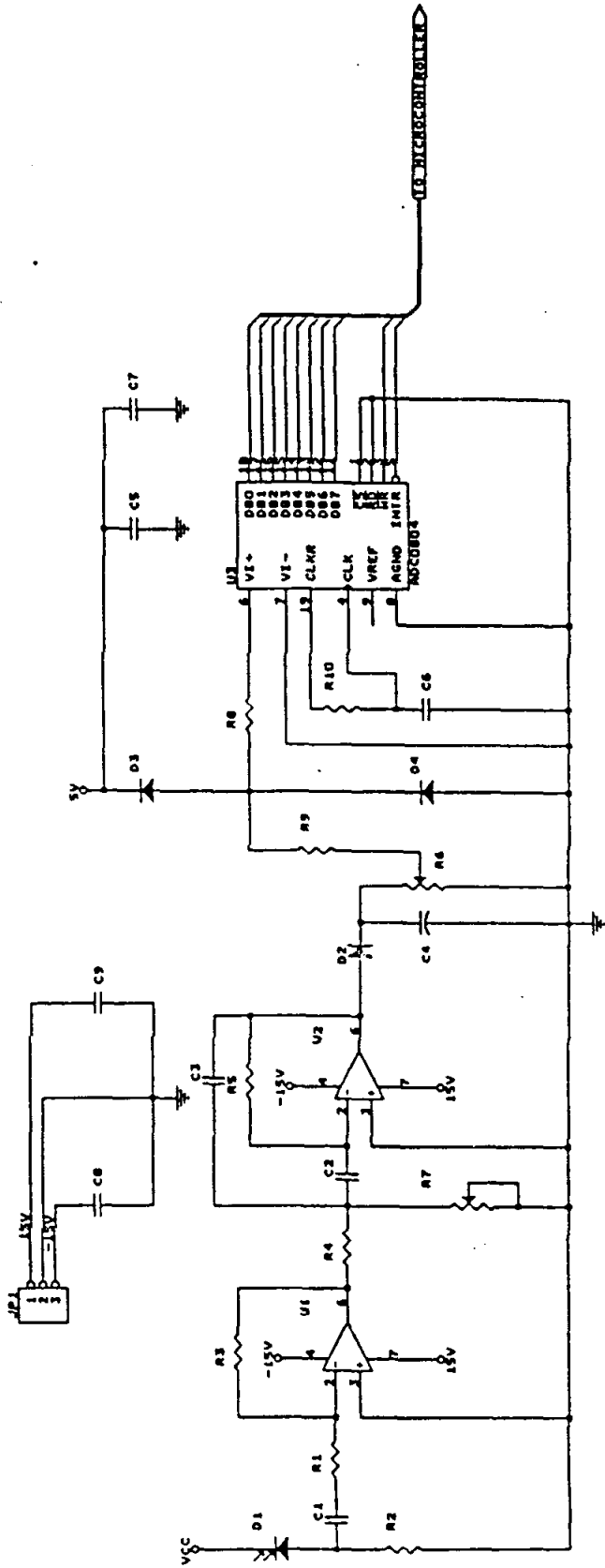

LAMPIRAN A

RANGKAIAN SKEMATIK



DAFTAR KOMPONEN

GAMBAR RANGKAIAN I

C1 = 10 nF
C2 = 1 nF
C3 = 1 nF
C4 = 10 nF
C5 = 100 nF
C6 = 10 nF
C7 = 100 nF
C8 = 100 nF
C9 = 100 nF

D1 = 1N4148
D2 = 1N4148
D3 = 1N4148
D4 = 1N4148

R1 = 22 K Ω
R2 = 47 K Ω
R3 = 4,7 M Ω
R4 = 47 K Ω
R5 = 1 M Ω
R6 = 100 K Ω
R7 = 5 K Ω
R8 = 470 Ω
R9 = 470 Ω
R10 = 10 K Ω

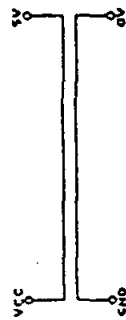
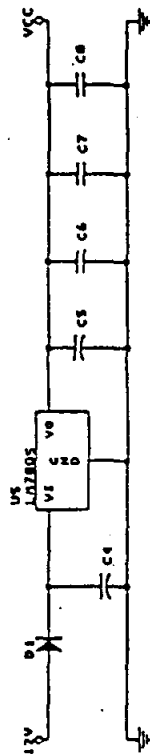
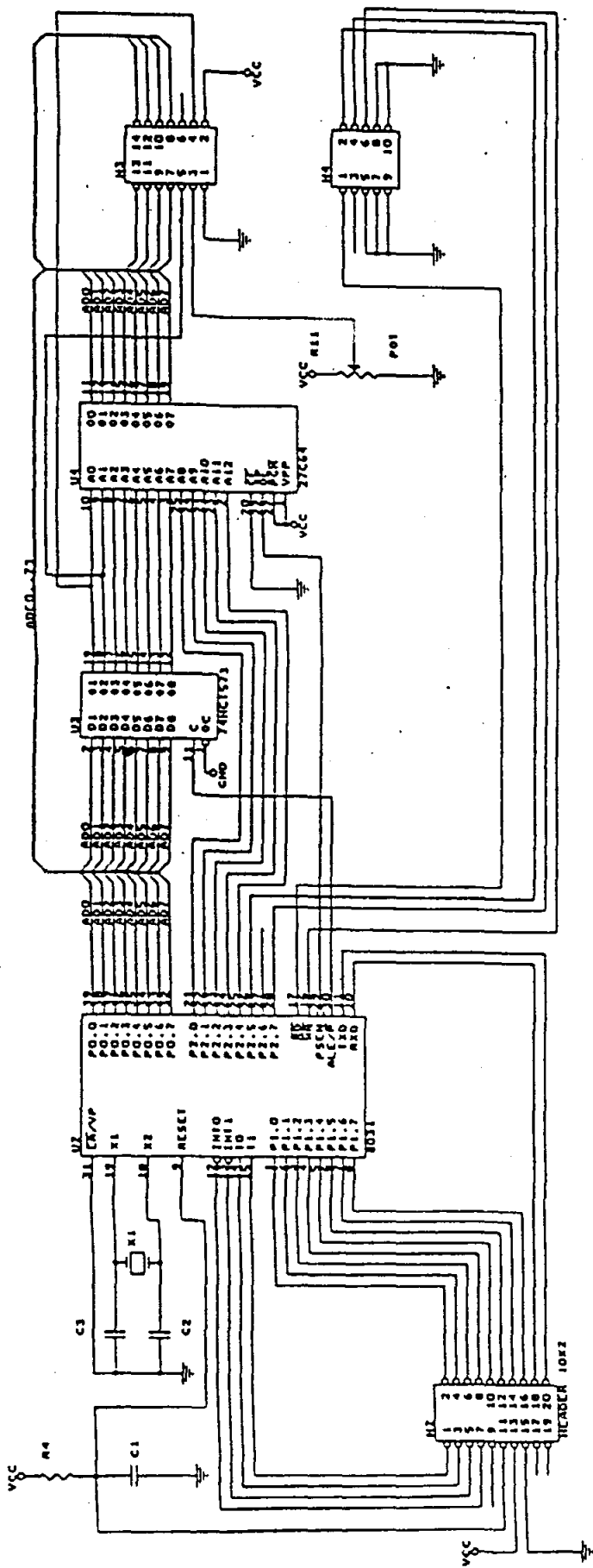

DAFTAR KOMPONEN GAMBAR RANGKAIAN II

C1 = 10 μ F
C2 = 22 pF
C3 = 22 pF
C4 = 2200 μ F / 25 Volt
C5 = 1000 μ F / 16 Volt
C6 = 100 nF
C7 = 100 nF
C8 = 100 nF

D1 = 1N4148

R4 = 10 K Ω
R11 = 100 K Ω
X1 = 14 MHz

8751BH SINGLE-CHIP 8-BIT MICROCOMPUTER WITH 4K BYTES OF EPROM PROGRAM MEMORY

- | | |
|---|--|
| <ul style="list-style-type: none"> ■ Program Memory Lock ■ 128 Bytes Data Ram ■ Quick Pulse Programming™ Algorithm ■ 12.75 Volt Programming Voltage ■ Boolean Processor ■ 32 Programmable I/O Lines | <ul style="list-style-type: none"> ■ Two 16-Bit Timer/Counters ■ 5 Interrupt Sources ■ Programmable Serial Channel ■ 64K External Program Memory Space ■ 64K External Data Memory Space |
|---|--|

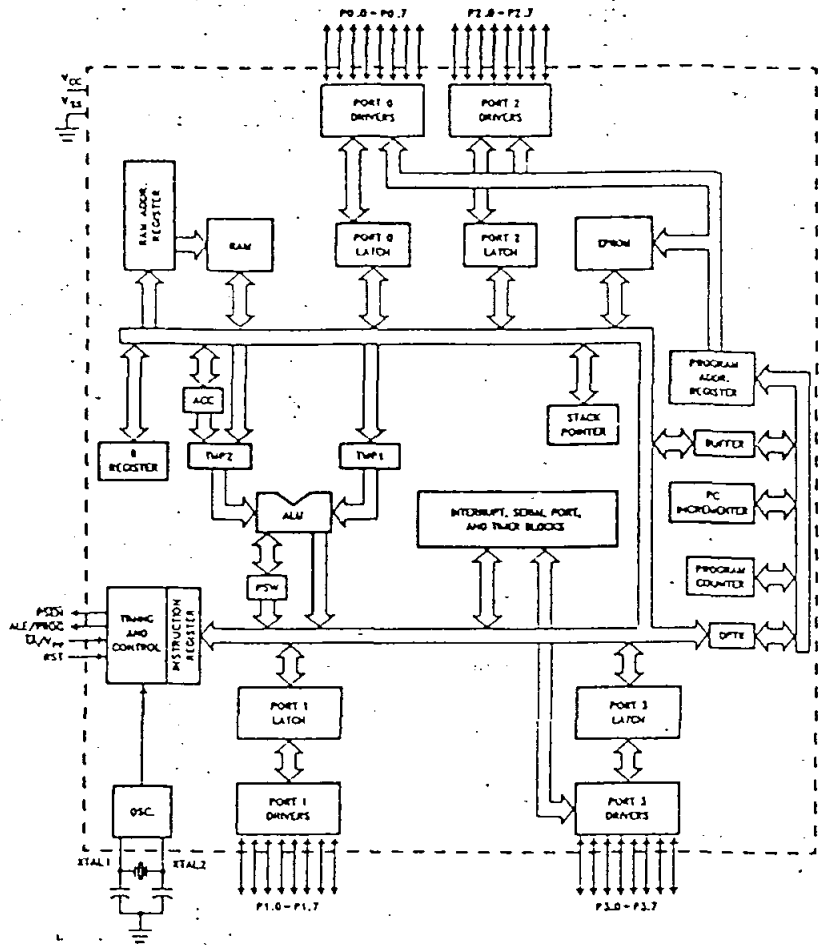

Figure 1. 8751BH Block Diagram

270248-1

PACKAGES

Part	Prefix	Package Type
8751BH	P	40-Pin Plastic DIP
	N	44-Pin PLCC

PIN DESCRIPTIONS

V_{CC}: Supply voltage.

V_{SS}: Circuit ground.

Port 0: Port 0 is an 8-bit open drain bidirectional I/O port. As an output port each pin can sink 8 LS TTL inputs. Port 0 pins that have 1s written to them float, and in that state can be used as high-impedance inputs.

Port 0 is also the multiplexed low-order address and data bus during accesses to external Program and Data Memory. In this application it uses strong internal pullups when emitting 1s, and can source and sink 8 LS TTL inputs.

Port 0 also receives the code bytes during EPROM programming, and outputs the code bytes during program verification. External pullups are required during program verification.

Port 1: Port 1 is an 8-bit bidirectional I/O port with internal pullups. The Port 1 output buffers can sink/source 4 LS TTL inputs. Port 1 pins that have 1s written to them are pulled high by the internal pullups, and in that state can be used as inputs. As inputs, Port 1 pins that are externally being pulled low will source current (I_{IL} on the data sheet) because of the internal pullups.

Port 1 also receives the low-order address bytes during EPROM programming and program verification.

Port 2: Port 2 is an 8-bit bidirectional I/O port with internal pullups. The Port 2 output buffers can sink/source 4 LS TTL inputs. Port 2 pins that have 1s written to them are pulled high by the internal pullups, and in that state can be used as inputs. As inputs, Port 2 pins that are externally being pulled low will source current (I_{IL} on the data sheet) because of the internal pullups.

Port 2 emits the high-order address byte during fetches from external Program Memory and during accesses to external Data Memory that use 16-bit addresses (MOVX @DPTR). In this application it uses strong internal pullups when emitting 1s. During accesses to external Data Memory that use 8-bit addresses (MOVX @Ri), Port 2 emits the contents of the P2 Special Function Register.

Port 2 also receives the high-order address bits during EPROM programming and program verification.

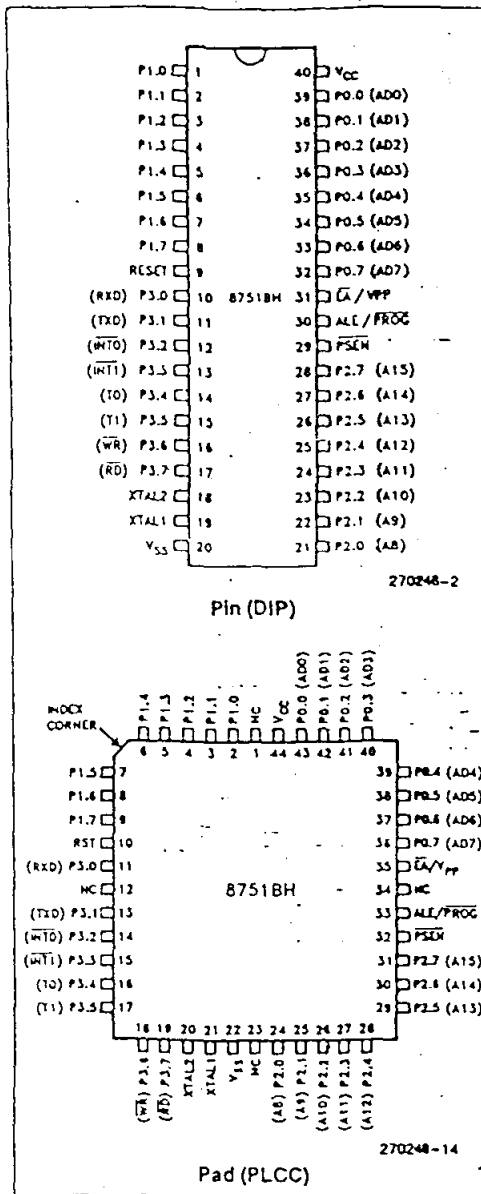

Figure 2. Pin Connections

Port 3: Port 3 is an 8-bit bidirectional I/O port with internal pullups. The Port 3 output buffers can sink/source 4 LS TTL inputs. Port 3 pins that have 1s written to them are pulled high by the internal pullups, and in that state can be used as inputs. As inputs, Port 3 pins that are externally being pulled low will source current (I_{OL} on the data sheet) because of the pullups.

Port 3 also serves the functions of various special features of the MCS[®]-51 Family, as listed below:

Port Pin	Alternate Function
P3.0	RXD (serial input port)
P3.1	TXD (serial output port)
P3.2	$\overline{INT0}$ (external interrupt 0)
P3.3	$\overline{INT1}$ (external interrupt 1)
P3.4	T0 (Timer 0 external input)
P3.5	T1 (Timer 1 external input)
P3.6	\overline{WR} (external data memory write strobe)
P3.7	\overline{RD} (external data memory read strobe)

RST: Reset input. A high on this pin for two machine cycles while the oscillator is running resets the device.

ALE/ \overline{PROG} : Address Latch Enable output pulse for latching the low byte of the address during accesses to external memory. This pin is also the program pulse input (\overline{PROG}) during EPROM programming.

In normal operation ALE is emitted at a constant rate of 1/6 the oscillator frequency, and may be used for external timing or clocking purposes. Note, however, that one ALE pulse is skipped during each access to external Data Memory.

\overline{PSEN} : Program Store Enable is the Read strobe to External Program Memory.

When the 8751BH is executing code from external Program Memory, \overline{PSEN} is activated twice each machine cycle, except that two \overline{PSEN} activations are skipped during each access to External Data Memory.

\overline{EA}/V_{PP} : External Access enable. \overline{EA} must be strapped to V_{SS} in order to enable the device to fetch code from External Program Memory locations starting at 0000H up to FFFFH. Note, however, that if either of the Lock Bits are programmed, \overline{EA} will be internally latched on reset.

\overline{EA} should be strapped to V_{CC} for internal program executions.

This pin also receives the 12.75V programming supply voltage (V_{PP}) during EPROM programming.

XTAL1: Input to the inverting oscillator amplifier.

XTAL2: Output from the inverting oscillator amplifier.

OSCILLATOR CHARACTERISTICS

XTAL1 and XTAL2 are the input and output, respectively, of an inverting amplifier which can be configured for use as an on-chip oscillator, as shown in Figure 3. Either a quartz crystal or ceramic resonator may be used. More detailed information concerning the use of the on-chip oscillator is available in Applications Note AP-155, "Oscillators for Microcontrollers."

To drive the device from an external clock source, XTAL1 should be grounded, while XTAL2 is driven, as shown in Figure 4. There are no requirements on the duty cycle of the external clock signal, since the input to the internal clocking circuitry is through a divide-by-two flip-flop, but minimum and maximum high and low times specified on the Data Sheet must be observed.

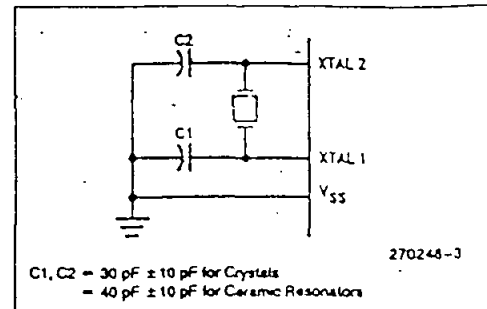

C1, C2 = 30 pF ± 10 pF for Crystals
= 40 pF ± 10 pF for Ceramic Resonators

Figure 3. Oscillator Connections

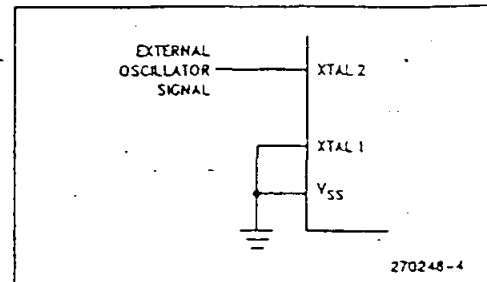

Figure 4. External Clock Drive Configuration

DESIGN CONSIDERATIONS

If an 8751BH is replacing an 8751H in an existing design, the user should carefully compare both data sheets for DC or AC Characteristic differences. Note that the V_{IH} and I_{IH} specifications for the EA pin differ significantly between the 8751H and 8751BH.

ABSOLUTE MAXIMUM RATINGS*

Ambient Temperature Under Bias 0°C to +70°C
 Storage Temperature -65°C to +150°C
 Voltage on \overline{EA} /Vpp Pin to V_{SS} . . . -0.5V to +13.0V
 Voltage on Any Other Pin to V_{SS} -0.5V to +7V
 Maximum I_{OL} Per I/O Pin 15 mA
 Power Dissipation 1.5W
 (based on PACKAGE heat transfer limitations, not
 device power consumption)

*Notice: Stresses above those listed under "Absolute Maximum Ratings" may cause permanent damage to the device. This is a stress rating only and functional operation of the device at these or any other conditions above those indicated in the operational sections of this specification is not implied. Exposure to absolute maximum rating conditions for extended periods may affect device reliability.

NOTICE: Specifications contained within the following tables are subject to change.

C. CHARACTERISTICS ($T_A = 0^\circ\text{C}$ to $+70^\circ\text{C}$; $V_{CC} = 5V \pm 10\%$; $V_{SS} = 0V$)

Symbol	Parameter	Min	Max	Unit	Test Conditions
V_{IL}	Input Low Voltage (Except \overline{EA})	-0.5	0.8	V	
V_{IL1}	Input Low Voltage \overline{EA}	V_{SS}	0.7	V	
V_{IH}	Input High Voltage (Except XTAL2, RST, \overline{EA})	2.0	$V_{CC} + 0.5$	V	
V_{IH1}	Input High Voltage XTAL2, RST	2.5	$V_{CC} + 0.5$	V	XTAL1 = V_{SS}
V_{IH2}	Input High Voltage to \overline{EA}	4.5	5.5	V	
V_{OL}	Output Low Voltage (Note 3) (Ports 1, 2 and 3)		0.45	V	$I_{OL} = 1.6$ mA (Note 1)
V_{OL1}	Output Low Voltage (Note 3) (Port 0, ALE/ $\overline{P\overline{R}O\overline{G}}$, $\overline{P\overline{S}EN}$)		0.45	V	$I_{OL} = 3.2$ mA (Notes 1, 2)
V_{OH}	Output High Voltage (Ports 1, 2, 3, ALE/ $\overline{P\overline{R}O\overline{G}}$ and $\overline{P\overline{S}EN}$)	2.4		V	$I_{OH} = -80$ μ A
V_{OH1}	Output High Voltage (Port 0 in External Bus Mode)	2.4		V	$I_{OH} = -400$ μ A
I_{IL}	Logical 0 Input Current (Ports 1, 2, 3 and RST)		-1	mA	$V_{IN} = 0.45V$
I_{IL1}	Logical 0 Input Current (\overline{EA})	-	-10	mA	$V_{IN} = V_{SS}$
I_{IL2}	Logical 0 Input Current (XTAL2)		-3.2	mA	$V_{IN} = 0.45V$ XTAL1 = V_{SS}
I_{LI}	Input Leakage Current (Port 0)		± 10	μ A	$0.45 < V_{IN} < V_{CC}$
I_{IH}	Logical 1 Input Current (\overline{EA})		1	mA	$4.5V < V_{IN} < 5.5V$
I_{IH1}	Input Current to RST to Activate Reset		500	μ A	$V_{IN} < (V_{CC} - 1.5V)$
I_{CC}	Power Supply Current		175	mA	All Outputs Disconnected
C_{IO}	Pin Capacitance		10	pF	Test Freq = 1MHz

NOTES:

1. Capacitive loading on Ports 0 and 2 may cause spurious noise pulses to be superimposed on the V_{OL} s of ALE/ $\overline{P\overline{R}O\overline{G}}$ and Ports 1 and 3. The noise is due to external bus capacitance discharging into the Port 0 and Port 2 pins when these pins make 1-to-0 transitions during bus operations. In the worst cases (capacitive loading > 100 pF), the noise pulse on the ALE/ $\overline{P\overline{R}O\overline{G}}$ pin may exceed 0.6V. In such cases it may be desirable to qualify ALE with a Schmitt Trigger, or use an address latch with a Schmitt Trigger STROBE input.

2. ALE/ $\overline{P\overline{R}O\overline{G}}$ refers to a pin on the 8751BH. ALE refers to a timing signal that is output on the ALE/ $\overline{P\overline{R}O\overline{G}}$ pin.

3. Under steady state (non-transient) conditions, I_{OL} must be externally limited as follows:

Maximum I_{OL} per port pin: 10 mA

Maximum I_{OL} per 8-bit port:

Port 0: 26 mA

Ports 1, 2, and 3: 15 mA

Maximum total I_{OL} for all output pins: 71 mA

4. If I_{OL} exceeds the test condition, V_{OL} may exceed the related specification. Pins are not guaranteed to sink current greater than the listed test conditions.

A.C. CHARACTERISTICS ($T_A = 0^\circ\text{C}$ to $+70^\circ\text{C}$; $V_{CC} = 5V \pm 10\%$; $V_{SS} = 0V$); Load Capacitance for Port 0, ALE/PROG, and PSEN = 100 pF; Load Capacitance for All Other Outputs = 80 pF

EXTERNAL PROGRAM MEMORY CHARACTERISTICS

Symbol	Parameter	12 MHz Osc		Variable Oscillator		Units
		Min	Max	Min	Max	
1/TCLCL	Oscillator Frequency			3.5	12.0	MHz
TLHLL	ALE Pulse Width	127		2TCLCL - 40		ns
TAVLL	Address Valid to ALE Low	43		TCLCL - 40		ns
TLLAX	Address Hold After ALE Low	48		TCLCL - 35		ns
TLLIV	ALE Low to Valid Instruction In		233		4TCLCL - 100	ns
TLLPL	ALE Low to PSEN Low	58		TCLCL - 25		ns
TPLPH	PSEN Pulse Width	215		3TCLCL - 35		ns
TPLIV	PSEN Low to Valid Instruction In		125		3TCLCL - 125	ns
TPXIX	Input Instr Hold After PSEN	0		0		ns
TPXIZ	Input Instr Float After PSEN		63		TCLCL - 20	ns
TPXAV	PSEN to Address Valid	75		TCLCL - 8		ns
TAVIV	Address to Valid Instruction In		302		5TCLCL - 115	ns
TPLAZ	PSEN Low to Address Float		20		20	ns
TRLRH	RD Pulse Width	400		6TCLCL - 100		ns
TWLWH	WR Pulse Width	400		6TCLCL - 100		ns
TRLDV	RD Low to Valid Data In		252		5TCLCL - 165	ns
TRHOX	Data Hold After RD	0		0		ns
TRHDZ	Data Float After RD		97		2TCLCL - 70	ns
TLLDV	ALE Low to Valid Data In		517		8TCLCL - 150	ns
TAVDV	Address to Valid Data In		585		9TCLCL - 165	ns
TLLWL	ALE Low to RD or WR Low	200	300	3TCLCL - 50	3TCLCL + 50	ns
TAVWL	Address to RD or WR Low	203		4TCLCL - 130		ns
TQVWX	Data Valid to WR Transition	23		TCLCL - 60		ns
TQVWH	Data Valid to WR High	433		7TCLCL - 150		ns
TWHOX	Data Held After WR	33		TCLCL - 50		ns
TRLAZ	RD Low to Address Float		0		0	ns
TWHLH	RD or WR High to ALE High	43	123	TCLCL - 40	TCLCL + 40	ns

67

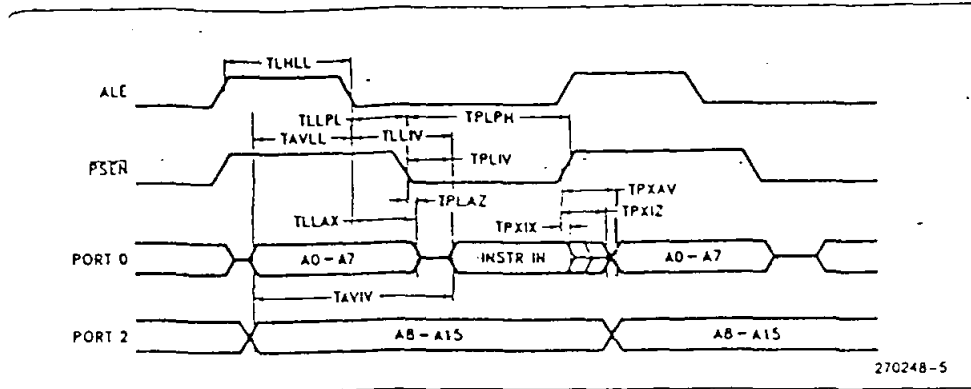

External Program Memory Read Cycle

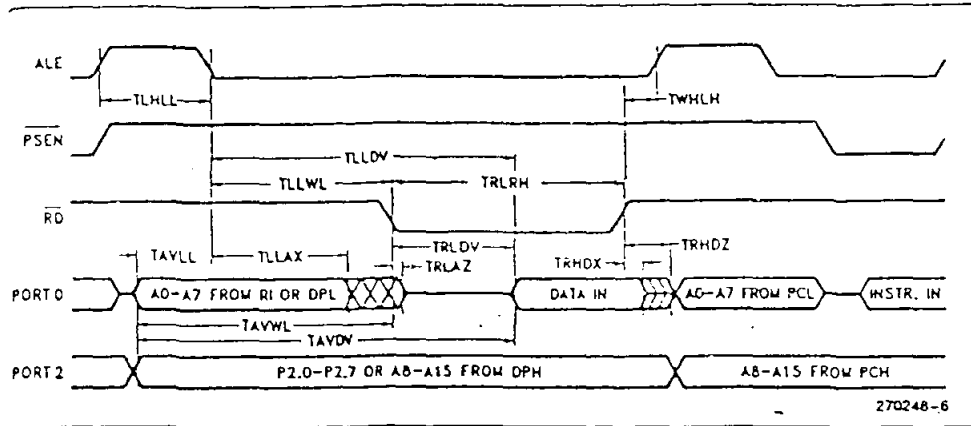

External Data Memory Read Cycle

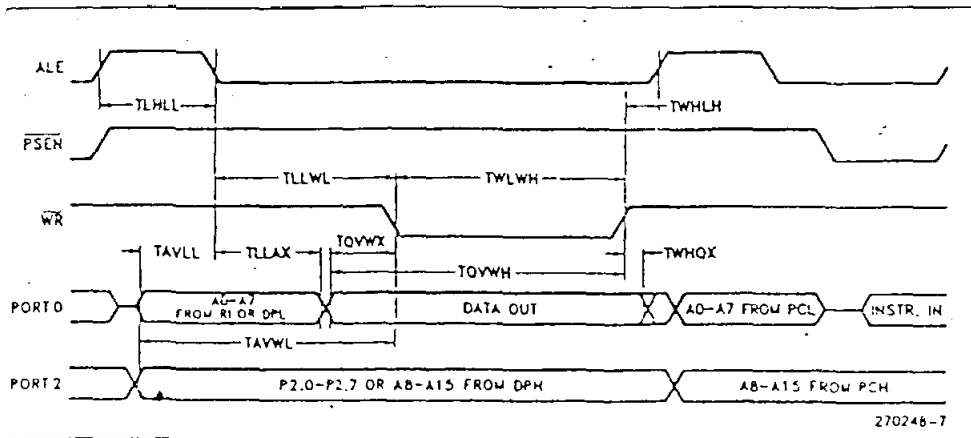

External Data Memory Write Cycle

SERIAL PORT TIMING — SHIFT REGISTER MODE

TEST CONDITIONS ($T_A = 0^{\circ}\text{C to } +70^{\circ}\text{C}$; $V_{CC} = 5\text{V} \pm 10\%$; $V_{SS} = 0\text{V}$; Load Capacitance = 80 pF)

Symbol	Parameter	12MHz Osc		Variable Oscillator		Units
		Min	Max	Min	Max	
TXLXL	Serial Port Clock Cycle Time	1.0		12TCLCL		μs
TOVXH	Output Data Setup to Clock Rising Edge	700		10TCLCL - 133		ns
TXHOX	Output Data Hold After Clock Rising Edge	50		2TCLCL - 117		ns
TXHDX	Input Data Hold After Clock Rising Edge	0		0		ns
TXHDV	Clock Rising Edge to Input Data Valid		700		10TCLCL - 133	ns

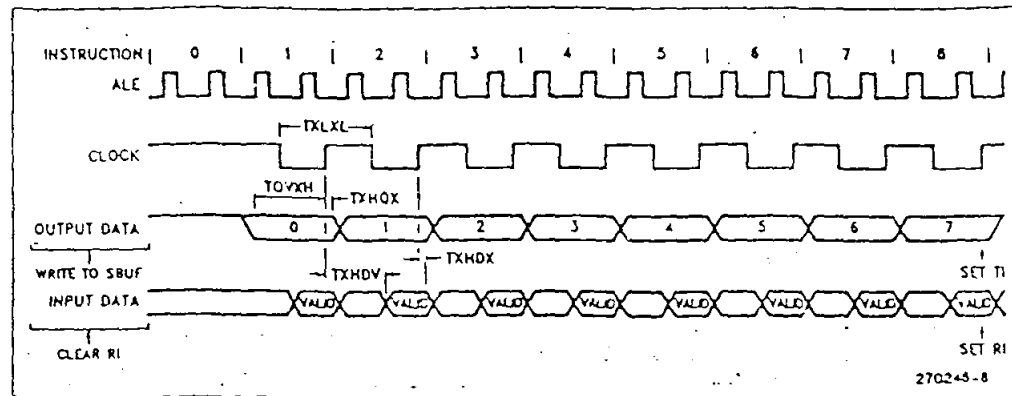

Shift Register Mode Timing Waveforms

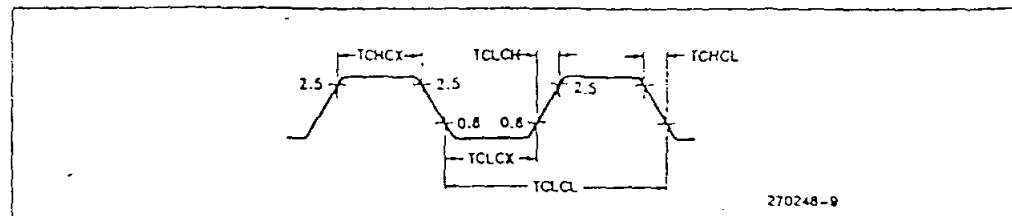

External Clock Drive Waveforms

EXTERNAL CLOCK DRIVE

Symbol	Parameter	Min	Max	Units
1/TCLCL	Oscillator Frequency	3.5	12	MHz
TCHCX	High Time	20		ns
TCLCX	Low Time	20		ns
TCLCH	Rise Time		20	ns
TCHCL	Fall Time		20	ns

EPROM CHARACTERISTICS

Programming the EPROM

To be programmed, the part must be running with a 4 to 6 MHz oscillator. (The reason the oscillator needs to be running is that the internal bus is being used to transfer address and program data to appropriate internal registers.) The address of an EPROM location to be programmed is applied to Port 1 and pins P2.0 - P2.3 of Port 2, while the code byte to be programmed into that location is applied to Port 0. The other Port 2 and 3 pins, and RST, PSEN, and EA/Vpp should be held at the "Program" levels indicated in Table 1. ALE/PROG is pulsed low to program the code byte into the addressed EPROM location. The setup is shown in Figure 5.

Normally EA/Vpp is held at a logic high until just before ALE/PROG is to be pulsed. Then EA/Vpp is raised to Vpp, ALE/PROG is pulsed low, and then EA/Vpp is returned to a valid high voltage. The voltage on the EA/Vpp pin must be at the valid EA/Vpp high level before a verify is attempted. Waveforms and detailed timing specifications are shown in later sections of this data sheet.

Note that the EA/Vpp pin must not be allowed to go above the maximum specified Vpp level for any

AC TESTING INPUT/OUTPUT WAVEFORMS

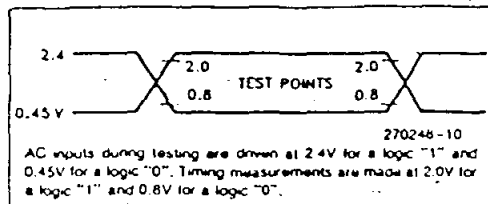

amount of time. Even a narrow glitch above that voltage level can cause permanent damage to the device. The Vpp source should be well regulated and free of glitches.

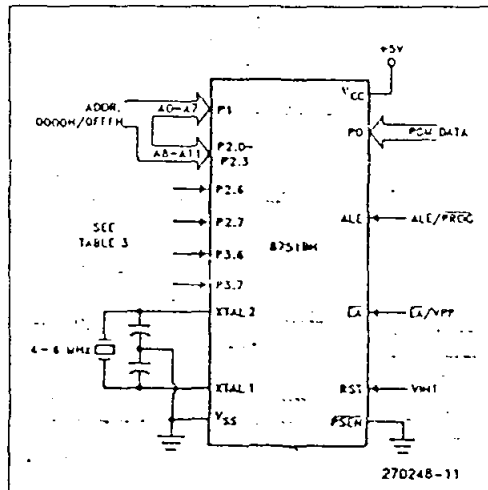

Figure 5. Programming the EPROM

Table 1. EPROM Programming Modes

MODE	RST	$\overline{\text{PSEN}}$	ALE/ PROG	EA/ V _{pp}	P2.7	P2.6	P3.6	P3.7
Program Code Data	1	0	0*	V _{pp}	1	0	1	1
Verify Code Data	1	0	1	1	0	0	1	1
Program Encryption Table Use Addresses 0-1FH	1	0	0*	V _{pp}	1	0	0	1
Program Lock x = 1	1	0	0*	V _{pp}	1	1	1	1
Bits (LBx) x = 2	1	0	0*	V _{pp}	1	1	0	0
Read Signature	1	0	1	1	0	0	0	0

NOTES:

"1" = Valid high for that pin

"0" = Valid low for that pin

"V_{pp}" = +12.75V ±0.25V

* ALE/PROG is pulsed low for 100 µs for programming. (Quick-Pulse Programming™)

QUICK-PULSE PROGRAMMING™
ALGORITHM

The 8751BH can be programmed using the Quick-Pulse Programming Algorithm for microcontrollers. The features of the new programming method are a lower V_{pp} (12.75 volts as compared to 21 volts) and a shorter programming pulse. It is possible to program the entire 4K Bytes of EPROM memory in less than 13 seconds with this algorithm.

To program the part using the new algorithm, V_{pp} must be 12.75 ± 0.25 Volts. ALE/PROG is pulsed low for 100 µseconds, 25 times. Then, the byte just programmed may be verified. After programming, the entire array should be verified. The Program Lock features are programmed using the same method, but with the setup as shown in Table 1. The only difference in programming Lock features is that the Lock features cannot be directly verified. Instead, verification of programming is by observing that their features are enabled.

PROGRAM VERIFICATION

If the Lock Bits have not been programmed, the on-chip Program Memory can be read out for verification purposes, if desired, either during or after the programming operation. The address of the Program Memory location to be read is applied to Port 1 and pins P2.0 - P2.3. The other pins should be held at the "Verify" levels indicated in Table 1. The con-

tents of the addressed location will come out on Port 0. External pullups are required on Port 0 for this operation. (If the Encryption Array in the EPROM has been programmed, the data present at Port 0 will be Code Data XOR Encryption Data. The user must know the Encryption Array contents to manually "unencrypt" the data during verify.)

The setup, which is shown in Figure 6, is the same as for programming the EPROM except that pin P2.7 is held at a logic low, or may be used as an active low read strobe.

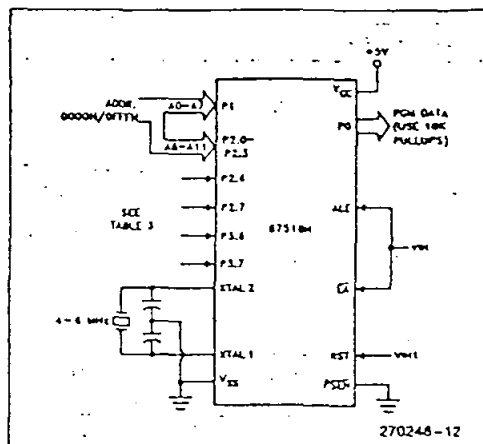

Figure 6. Verifying the EPROM

PROGRAM MEMORY LOCK

The two-level Program Lock system consists of 2 Lock bits and a 32-byte Encryption Array which are used to protect the program memory against software piracy.

Encryption Array

Within the EPROM array are 32 bytes of Encryption Array that are initially unprogrammed (all 1s). Every time that a byte is addressed during a verify, 5 address lines are used to select a byte of the Encryption Array. This byte is then exclusive-NORed (XNOR) with the code byte, creating an Encrypted Verify byte. The algorithm, with the array in the unprogrammed state (all 1s), will return the code in its original, unmodified form.

It is recommended that whenever the Encryption Array is used, at least one of the Lock Bits be programmed as well.

Lock Bits

Also included in the EPROM Program Lock scheme are two Lock Bits which function as shown in Table 2.

Table 2. Lock Bits and their Features

Lock Bits		Logic Enabled
LB1	LB2	
U	U	Minimum Program Lock features enabled. (Code Verify will still be encrypted by the Encryption Array)
P	U	MOVX instructions executed from external program memory are disabled from fetching code bytes from internal memory. EA is sampled and latched on reset, and further programming of the EPROM is disabled
P	P	Same as above, but Verify is also disabled
U	P	Reserved for Future Definition

P = Programmed
U = Unprogrammed

To ensure proper functionality of the chip, the internally latched value of the EA pin must agree with its external state.

ERASURE CHARACTERISTICS

This device is in a plastic package without a window and, therefore, cannot be erased.

Reading the Signature Bytes

The signature bytes are read by the same procedure as a normal verification of locations 030H and 031H, except that P3.6 and P3.7 need to be pulled to a logic low. The values returned are:

(030H) = 89H indicates manufactured by Intel
(031H) = 51H indicates 8751BH

EPROM PROGRAMMING AND VERIFICATION CHARACTERISTICS

($T_A = 21^\circ\text{C}$ to 27°C , $V_{CC} = 5.0\text{V} \pm 10\%$, $V_{SS} = 0\text{V}$)

Symbol	Parameter	Min	Max	Units
V_{pp}	Programming Supply Voltage	12.5	13.0	V
IPP	Programming Supply Current		50	mA
$1/TCLCL$	Oscillator Frequency	4	6	MHz
TAVGL	Address Setup to \overline{PROG} Low	48TCLCL		
TGHAX	Address Hold After \overline{PROG}	48TCLCL		
TDVGL	Data Setup to \overline{PROG} Low	48TCLCL		
TGHDX	Data Hold After \overline{PROG}	48TCLCL		
TEHSH	P2.7 (\overline{ENABLE}) High to V_{pp}	48TCLCL		
TSHGL	V_{pp} Setup to \overline{PROG} Low	10		μsec
TGHSL	V_{pp} Hold After \overline{PROG}	10		μsec
TGLGH	\overline{PROG} Width	90	110	μsec
TAVOV	Address to Data Valid		48TCLCL	
TELOV	\overline{ENABLE} Low to Data Valid		48TCLCL	
TEHOZ	Data Float After \overline{ENABLE}	0	48TCLCL	
TGHGL	\overline{PROG} High to \overline{PROG} Low	10		μsec

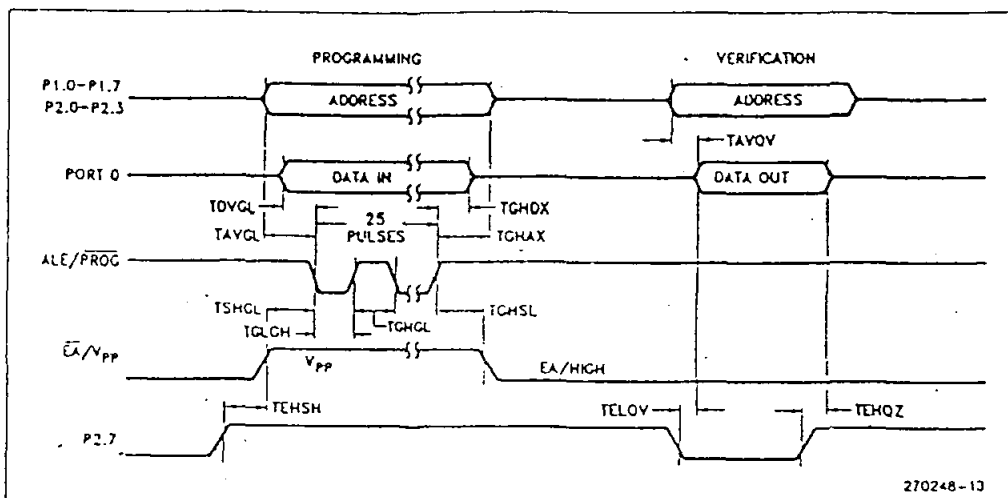

EPROM Programming and Verification Waveforms

ADC0801, ADC0802, ADC0803, ADC0804, ADC0805 8-Bit μ P Compatible A/D Converters

General Description

The ADC0801, ADC0802, ADC0803, ADC0804 and ADC0805 are CMOS 8-bit successive approximation A/D converters that use a differential potentiometric ladder—similar to the 256R products. These converters are designed to allow operation with the NSC800 and INS8080A derivative control bus with TRI-STATE[®] output latches directly driving the data bus. These A/Ds appear like memory locations or I/O ports to the microprocessor and no interfacing logic is needed.

Differential analog voltage inputs allow increasing the common-mode rejection and offsetting the analog zero input voltage value. In addition, the voltage reference input can be adjusted to allow encoding any smaller analog voltage span to the full 8 bits of resolution.

Features

- Compatible with 8080 μ P derivatives—no interfacing logic needed - access time - 135 ns
- Easy interface to all microprocessors, or operates "stand alone"

- Differential analog voltage inputs
- Logic inputs and outputs meet both MOS and TTL voltage level specifications
- Works with 2.5V (LM336) voltage reference
- On-chip clock generator
- 0V to 5V analog input voltage range with single 5V supply
- No zero adjust required
- 0.3" standard width 20-pin DIP package
- 20-pin molded chip carrier or small outline package
- Operates ratiometrically or with 5 V_{OC} , 2.5 V_{OC} , or analog span adjusted voltage reference

Key Specifications

- Resolution: 8 bits
- Total error: $\pm 1/4$ LSB, $\pm 1/2$ LSB and ± 1 LSB
- Conversion time: 100 μ s

Typical Applications

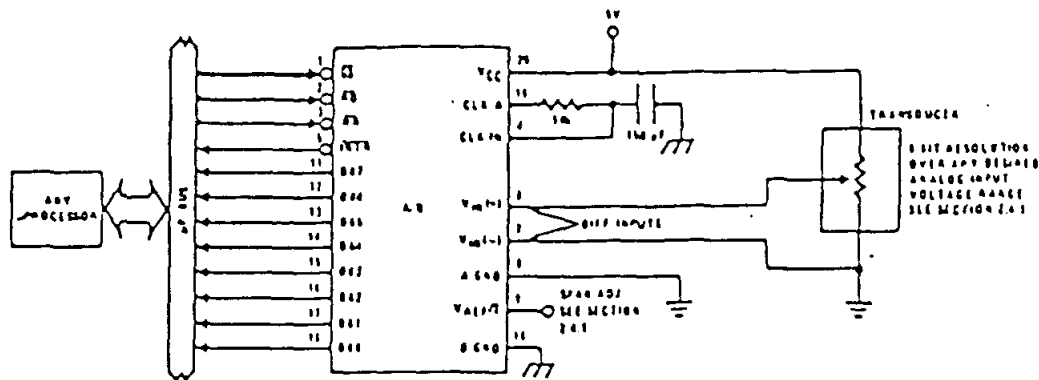

TU/M/5671-1

8080 Interface

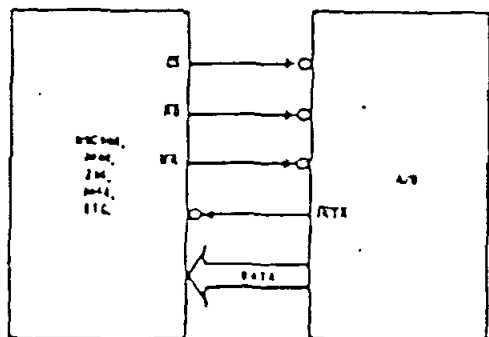

TU/M/5671-31

Error Specification (Includes Full-Scale, Zero Error, and Non-Linearity)

Part Number	Full-Scale Adjusted	$V_{REF}/2 = 2.500 V_{OC}$ (No Adjustments)	$V_{REF}/2 =$ No Connection (No Adjustments)
ADC0801	$\pm 1/4$ LSB		
ADC0802		$\pm 1/2$ LSB	
ADC0803	$\pm 1/2$ LSB		
ADC0804		± 1 LSB	
ADC0805			± 1 LSB

ADC0801/ADC0802/ADC0803/ADC0804/ADC0805

Absolute Maximum Ratings (Notes 1 & 2)

For Military/Aerospace specified devices are required, contact the National Semiconductor Sales Office/Distributors for availability and specifications.

Supply Voltage (V_{CC}) (Note 3)	6.5V
Logic Control Inputs	-0.3V to +18V
At Other Input and Outputs	-0.3V to ($V_{CC} + 0.3V$)
Lead Temp. (Soldering, 10 seconds)	260°C
Dual-In-Line Package (plastic)	300°C
Dual-In-Line Package (ceramic)	300°C
Surface Mount Package	
Vapor Phase (60 seconds)	215°C
Infrared (15 seconds)	220°C

Storage Temperature Range	-85°C to +150°C
Package Dissipation at $T_A = 25^\circ\text{C}$	875 mW
ESD Susceptibility (Note 10)	800V

Operating Ratings (Notes 1 & 2)

Temperature Range	$T_{MIN} \leq T_A \leq T_{MAX}$
ADC0801/02LJ	-55°C $\leq T_A \leq$ +125°C
ADC0801/02/03/04LCJ	-40°C $\leq T_A \leq$ +85°C
ADC0801/02/03/05LCN	-40°C $\leq T_A \leq$ +85°C
ADC0804LCN	0°C $\leq T_A \leq$ +70°C
ADC0802/03/04LCV	0°C $\leq T_A \leq$ +70°C
ADC0802/03/04LQWM	0°C $\leq T_A \leq$ +70°C
Range of V_{CC}	4.5 V_{CC} to 6.3 V_{CC}

Electrical Characteristics

The following specifications apply for $V_{CC} = 5 V_{CC}$, $T_{MIN} \leq T_A \leq T_{MAX}$ and $f_{CLK} = 640$ kHz unless otherwise specified.

Parameter	Conditions	Min	Typ	Max	Units
ADC0801: Total Adjusted Error (Note 8)	With Full-Scale Adj. (See Section 2.5.2)			$\pm 1/2$	LSB
ADC0802: Total Unadjusted Error (Note 8)	$V_{REF}/2 = 2.500 V_{CC}$			$\pm 1/2$	LSB
ADC0803: Total Adjusted Error (Note 8)	With Full-Scale Adj. (See Section 2.5.2)			$\pm 1/2$	LSB
ADC0804: Total Unadjusted Error (Note 8)	$V_{REF}/2 = 2.500 V_{CC}$			± 1	LSB
ADC0805: Total Unadjusted Error (Note 8)	$V_{REF}/2$ -No Connection			± 1	LSB
$V_{REF}/2$ Input Resistance (Pin 9)	ADC0801/02/03/05 ADC0804 (Note 9)	2.5 0.75	8.0 1.1		k Ω k Ω
Analog Input Voltage Range	(Note 4) $V(+)$ or $V(-)$	Gnd-0.05		$V_{CC} + 0.05$	V_{CC}
DC Common-Mode Error	Over Analog Input Voltage Range		$\pm 1/16$	$\pm 1/2$	LSB
Power Supply Sensitivity	$V_{CC} = 5 V_{CC} \pm 10\%$ Over Allowed $V_{IN}(+)$ and $V_{IN}(-)$ Voltage Range (Note 4)		$\pm 1/16$	$\pm 1/2$	LSB

AC Electrical Characteristics

The following specifications apply for $V_{CC} = 5 V_{CC}$ and $T_A = 25^\circ\text{C}$ unless otherwise specified.

Symbol	Parameter	Conditions	Min	Typ	Max	Units
T_C	Conversion Time	$f_{CLK} = 640$ kHz (Note 6)	103		114	μs
T_C	Conversion Time	(Note 5, 6)	66		73	$1/f_{CLK}$
f_{CLK}	Clock Frequency	$V_{CC} = 5V$, (Note 5)	100	640	1460	kHz
	Clock Duty Cycle	(Note 5)	40		60	%
CR	Conversion Rate in Free-Running Mode	INTR tied to WR with $\overline{CS} = 0 V_{CC}$, $f_{CLK} = 640$ kHz	8770		9708	conv/s
t_{WR}	Width of WR Input (Start Pulse Width)	$\overline{CS} = 0 V_{CC}$ (Note 7)	100			ns
t_{ACC}	Access Time (Delay from Falling Edge of RD to Output Data Valid)	$C_L = 100$ pF		135	200	ns
t_{H-Z}	TRI-STATE Control (Delay from Rising Edge of RD to Hi-Z State)	$C_L = 10$ pF, $R_L = 10k$ (See TRI-STATE Test Circuits)		125	200	ns
t_{RST}	Delay from Falling Edge of WR or RD to Reset of INTR			300	450	ns
C_{IN}	Input Capacitance of Logic Control Inputs			5	7.5	pF
C_{OUT}	TRI-STATE Output Capacitance (Data Buffers)			5	7.5	pF

CONTROL INPUTS (Note: CLK IN (Pin 4) is the input of a Schmitt trigger circuit and is therefore specified separately)

$V_{H(1)}$	Logical "1" Input Voltage (Except Pin 4 CLK IN)	$V_{CC} = 5.25 V_{CC}$	2.0		15	V_{CC}
------------	---	------------------------	-----	--	----	----------

AC Electrical Characteristics (Continued)

The following specifications apply for $V_{CC} = 5V_{CC}$ and $T_{MIN} \leq T_A \leq T_{MAX}$, unless otherwise specified.

Symbol	Parameter	Conditions	Min	Typ	Max	Units
CONTROL INPUTS [Note: CLK IN (Pin 4) is the input of a Schmitt trigger circuit and is therefore specified separately]						
$V_{IN}(0)$	Logical "0" Input Voltage (Except Pin 4 CLK IN)	$V_{CC} = 4.75 V_{CC}$			0.8	V_{CC}
$I_{IN}(1)$	Logical "1" Input Current (All Inputs)	$V_{IN} = 5 V_{CC}$		0.005	1	μA_{CC}
$I_{IN}(0)$	Logical "0" Input Current (All Inputs)	$V_{IN} = 0 V_{CC}$	-1	-0.005		μA_{CC}
CLOCK IN AND CLOCK R						
V_{T+}	CLK IN (Pin 4) Positive Going Threshold Voltage		2.7	3.1	3.5	V_{CC}
V_{T-}	CLK IN (Pin 4) Negative Going Threshold Voltage		1.5	1.8	2.1	V_{CC}
V_H	CLK IN (Pin 4) Hysteresis (V_{T+}) - (V_{T-})		0.6	1.3	2.0	V_{CC}
$V_{OUT}(0)$	Logical "0" CLK R Output Voltage	$I_O = 360 \mu A$ $V_{CC} = 4.75 V_{CC}$			0.4	V_{CC}
$V_{OUT}(1)$	Logical "1" CLK R Output Voltage	$I_O = -360 \mu A$ $V_{CC} = 4.75 V_{CC}$	2.4			V_{CC}
DATA OUTPUTS AND INTR						
$V_{OUT}(0)$	Logical "0" Output Voltage Data Outputs INTR Output	$I_{OUT} = 1.6 mA, V_{CC} = 4.75 V_{CC}$ $I_{OUT} = 1.0 mA, V_{CC} = 4.75 V_{CC}$			0.4 0.4	V_{CC} V_{CC}
$V_{OUT}(1)$	Logical "1" Output Voltage	$I_O = -360 \mu A, V_{CC} = 4.75 V_{CC}$	2.4			V_{CC}
$V_{OUT}(1)$	Logical "1" Output Voltage	$I_O = -10 \mu A, V_{CC} = 4.75 V_{CC}$	4.5			V_{CC}
I_{OUT}	TRI-STATE Disabled Output Leakage (All Data Buffers)	$V_{OUT} = 0 V_{CC}$ $V_{OUT} = 5 V_{CC}$	-3		3	μA_{CC} μA_{CC}
I_{SOURCE}		V_{OUT} Short to Gnd, $T_A = 25^\circ C$	4.5	6		mA_{CC}
I_{SINK}		V_{OUT} Short to V_{CC} , $T_A = 25^\circ C$	9.0	16		mA_{CC}
POWER SUPPLY						
I_{CC}	Supply Current (Includes Ladder Current) ADC0801/02/03/04LCJ/05 ADC0804LCN/LCV/LCWM	$f_{CLK} = 640 kHz$, $V_{REF}/2 = NC$, $T_A = 25^\circ C$ and $\overline{CS} = 5V$			1.1 1.9	1.8 2.5 mA mA

Note 1: Absolute Maximum Ratings indicate limits beyond which damage to the device may occur. DC and AC electrical specifications do not apply when operating the device beyond its specified operating conditions.

Note 2: All voltages are measured with respect to Gnd, unless otherwise specified. The separate A Gnd point should always be wired to the D Gnd.

Note 3: A zener diode exists internally from V_{CC} to Gnd and has a typical breakdown voltage of $7 V_{CC}$.

Note 4: For $V_{IN}(-) \geq V_{IN}(+)$ the digital output code will be 0000 0000. Two on-chip diodes are tied to each analog input (see block diagram) which will forward conduct for analog input voltages one diode drop below ground or one diode drop greater than the V_{CC} supply. Be careful, during testing at low V_{CC} levels (4.5V), as high level analog inputs (5V) can cause this input diode to conduct—especially at elevated temperatures, and cause errors for analog inputs near full-scale. The spec allows 50 mV forward bias of either diode. This means that as long as the analog V_{IN} does not exceed the supply voltage by more than 50 mV, the output code will be correct. To achieve an absolute 0 V_{CC} to 5 V_{CC} input voltage range will therefore require a minimum supply voltage of 4.950 V_{CC} over temperature variations, initial tolerance and loading.

Note 5: Accuracy is guaranteed at $f_{CLK} = 640 kHz$. At higher clock frequencies accuracy can degrade. For lower clock frequencies, the duty cycle limits can be extended so long as the minimum clock high time interval or minimum clock low time interval is no less than 275 ns.

Note 6: With an asynchronous start pulse, up to 8 clock periods may be required before the internal clock phases are proper to start the conversion process. The start request is internally latched, see Figure 2 and section 2.0.

Note 7: The \overline{CS} input is assumed to bracket the \overline{WR} strobe input and therefore timing is dependent on the \overline{WR} pulse width. An arbitrarily wide pulse width will hold the converter in a reset mode and the start of conversion is initiated by the low to high transition of the \overline{WR} pulse (see timing diagrams).

Note 8: None of these A/Ds requires a zero adjust (see section 2.5.1). To obtain zero code at other analog input voltages see section 2.5 and Figure 5.

Note 9: The $V_{REF}/2$ pin is the center point of a two resistor divider connected from V_{CC} to ground. Each resistor is 2.2k, except for the ADC0804LCJ where each resistor is 18k. Total ladder input resistance is the sum of the two equal resistors.

Typical Performance Characteristics

Logic Input Threshold Voltage vs. Supply Voltage

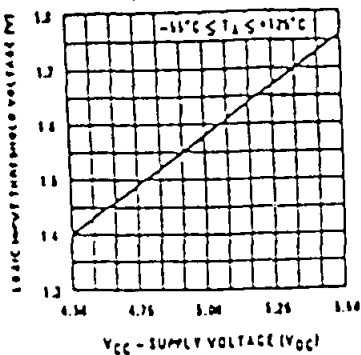

Delay From Falling Edge of RD to Output Data Valid vs. Load Capacitance

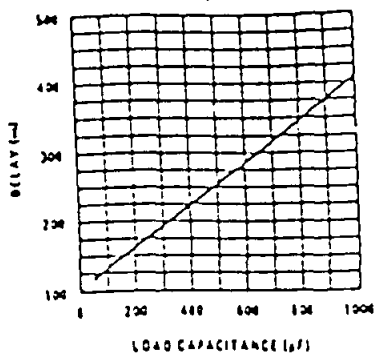

CLK IN Schmitt Trip Levels vs. Supply Voltage

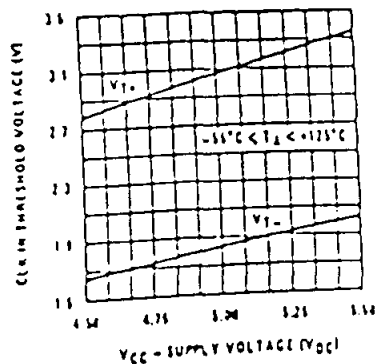

fCLK vs. Clock Capacitor

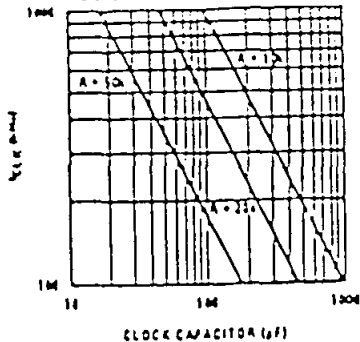

Full-Scale Error vs Conversion Time

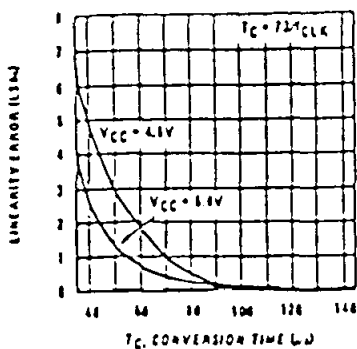

Effect of Unadjusted Offset Error vs. VREF/2 Voltage

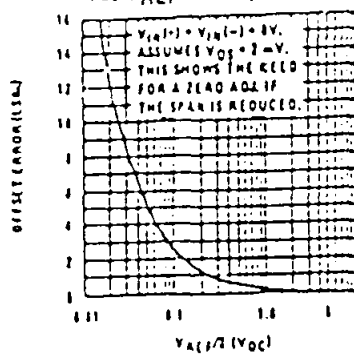

Output Current vs Temperature

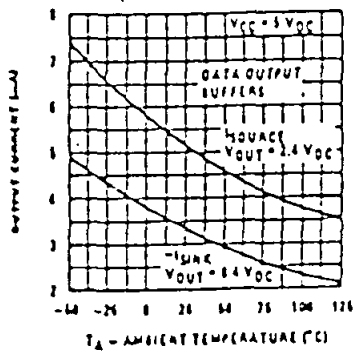

Power Supply Current vs Temperature (Note 9)

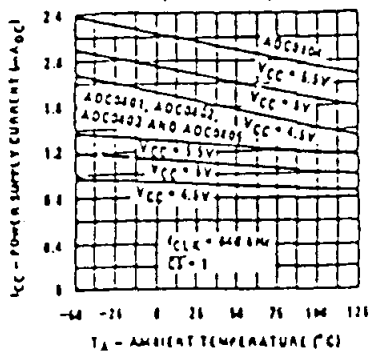

Linearity Error at Low VREF/2 Voltages

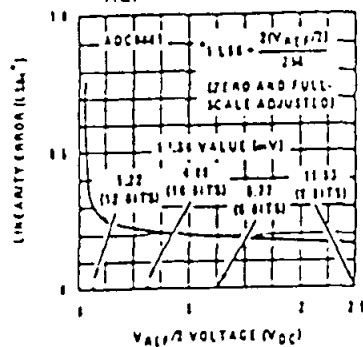

6300 Interface

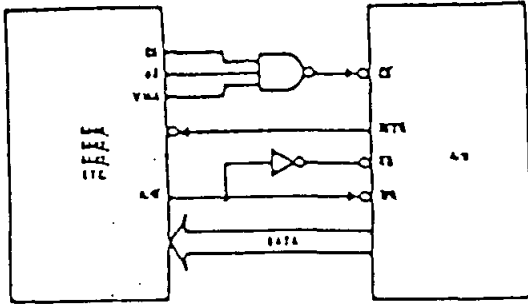

Ratiometric with Full-Scale Adjust

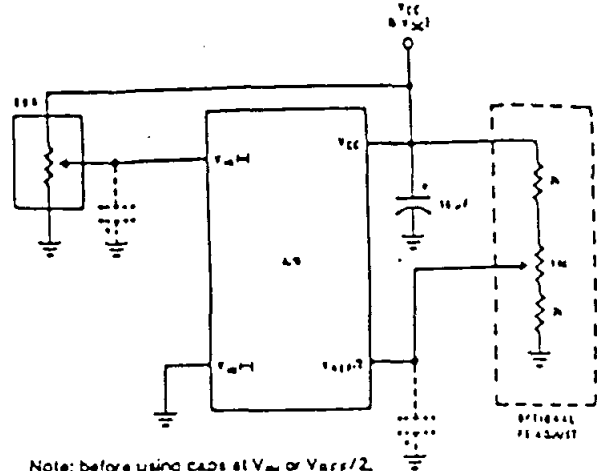

Note: before using caps at V_{IN} or V_{REF}/2, see section 2.3.2 Input Bypass Capacitors.

Absolute with a 2.500V Reference

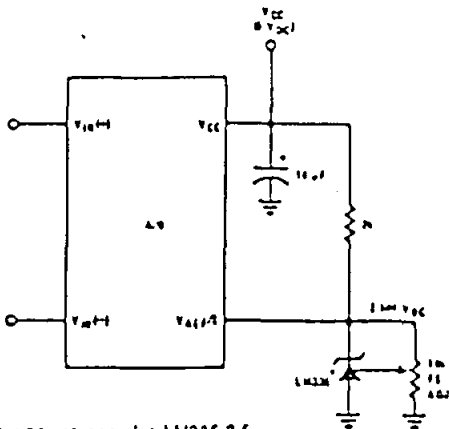

*For low power, see also LM385-2.5

Absolute with a 5V Reference

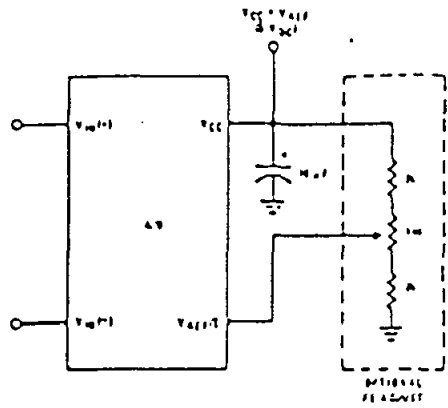

Zero-Shift and Span Adjust: 2V ≤ V_{IN} ≤ 5V

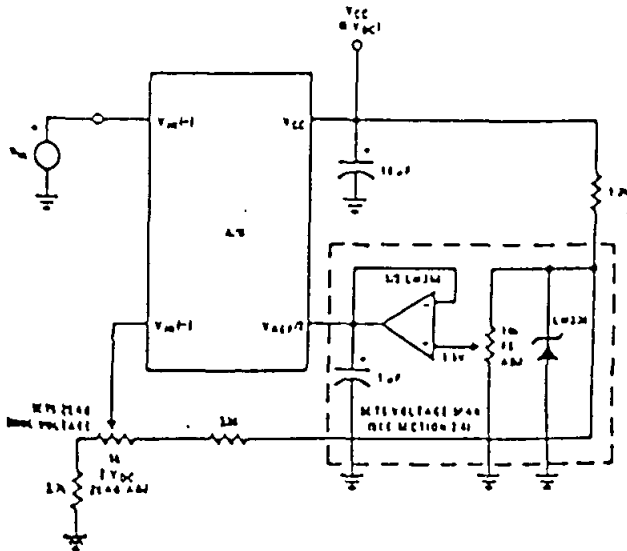

Span Adjust: 0V ≤ V_{IN} ≤ 3V

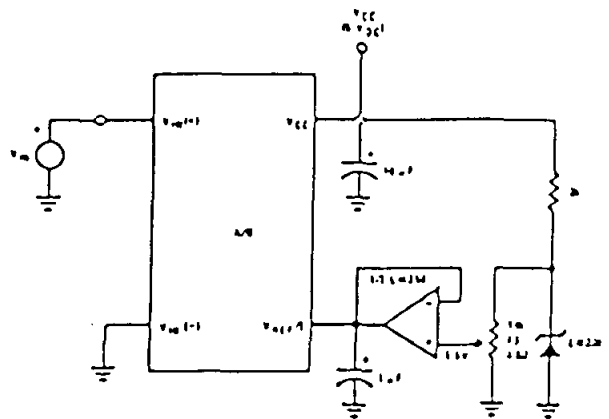

000001/ADUC0802/ADUC0803/ADUC0804/ADUC0805

TRI-STATE Test Circuits and Waveforms

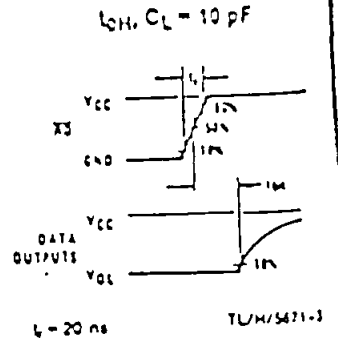
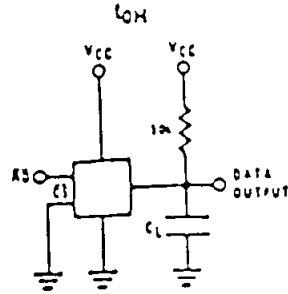
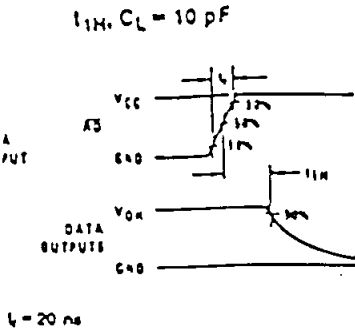
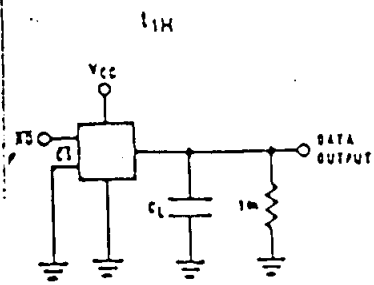

Timing Diagrams (All timing is measured from the 50% voltage points)

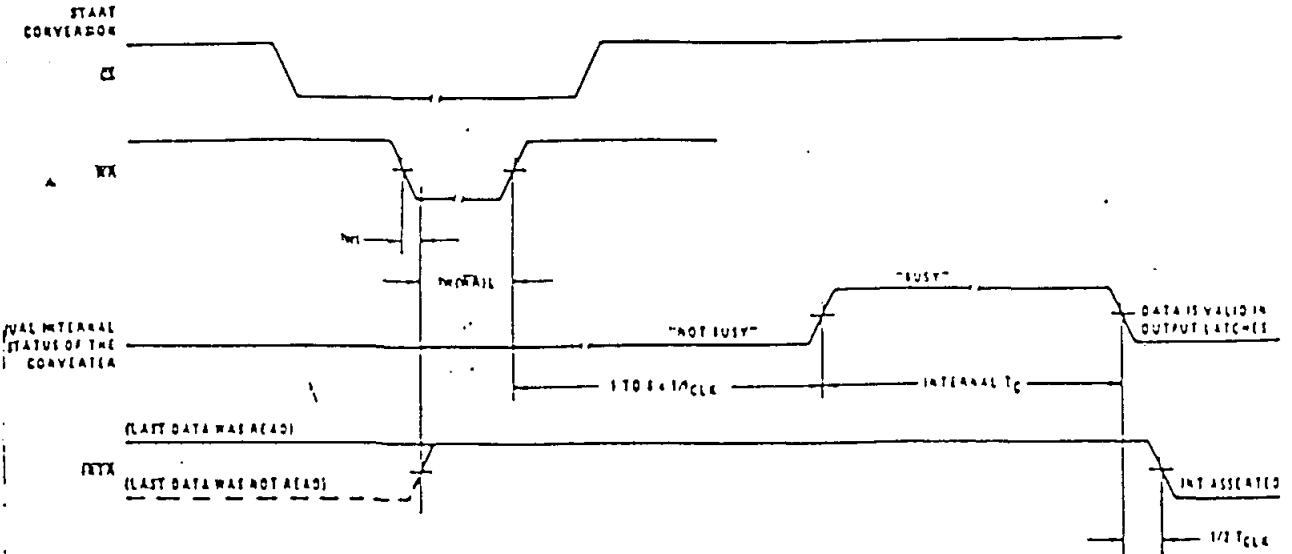

Output Enable and Reset \overline{INTX}

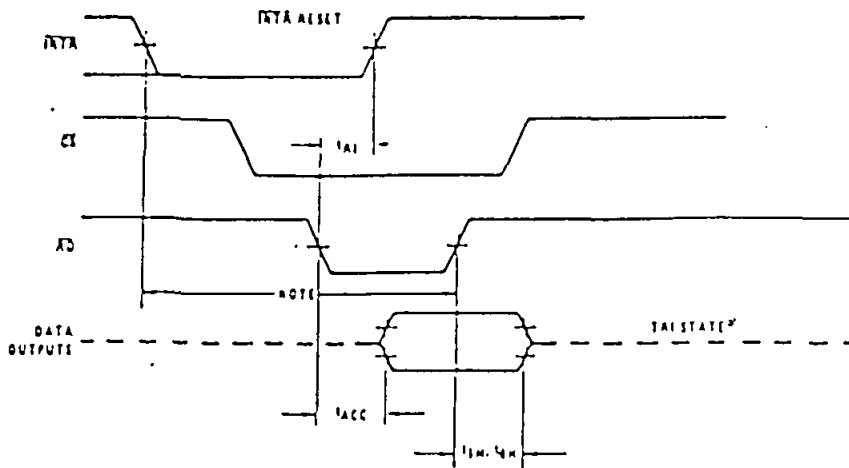

Note: Read strobe must occur 8 clock periods ($8/T_{CLK}$) after assertion of internal to guarantee reset of \overline{INTX} .

TUM/5671-4

LAMPIRAN B

PERANGKAT LUNAK

Listing programs

```

WR_CTRL_REG      EQU 2000H      % Inisialisasi prosesor 87C51 &
WR_DATA_REG      EQU 2001H      LCD %
RD_CTRL_REG      EQU 2002H
RD_DATA_REG      EQU 2003H
TIME_DELAY       EQU 21H
DSP1              EQU 22H
DSP2              EQU 23H
DSP3              EQU 24H
DSP4              EQU 25H
BUFFER           EQU 28H
INPUT            EQU 29H
PRINT_COUNTER    EQU 30H

```

```

ORG 0000H
AJMP MAIN

```

```

ORG 100H

```

```

MAIN:            MOV SP, #70H
                 ACALL INIT_LCD

                 MOV A, #00001100B
                 ACALL CTRL_OUT

```

```

LOGO:            ACALL CLEAR_DISPLAY % mencetak header logo %
                 ACALL PRT_TITLE1
                 ACALL DELAY_5S
                 ACALL CLEAR_DISPLAY
                 ACALL PRT_TITLE2
                 ACALL DELAY_5S

                 ACALL CLEAR_DISPLAY

```

```

MEASURE:        ACALL READ_P1      % membaca ADC dan
                 MOV BUFFER, INPUT % menampilkan di LCD %
                 ACALL TOTAL_RESULT
                 ACALL DELAY_2S
                 SJMP MEASURE

```

```

READ_P1:        PUSH DPH           % membaca pada Port P1 %
                 PUSH DPL
                 MOV A, P1
                 MOV INPUT, A

                 CLR C
                 SUBB A, #3
                 JNC REAL_DISP
                 MOV INPUT, #0
                 SJMP EXIT_RD_P1

```

```

REAL_DISP:      MOV A, #255
                 SUBB A, INPUT
                 MOV INPUT, A

```

Listing programs

```

                                CLR C
                                SUBB A, #200
                                JC LOW_DISP

HIGH_DISP:                      SJMP EXIT_RD_P1

LOW_DISP:                       MOV A, INPUT
                                MOV B, #6
                                DIV AB
                                MOV INPUT, A

EXIT_RD_P1:                     POP DPL
                                POP DPH
                                RET

TOTAL_RESULT:                   PUSH DPH                                % mencetak hasil
                                PUSH DPL                                pengukuran di LCD %

                                MOV R7, #0
                                ACALL LOCATE1
                                MOV DPTR, #OUTPUT
                                ACALL OUT_CHAR

                                MOV R7, #0
                                ACALL LOCATE2
                                MOV DPTR, #OUTPUT2
                                ACALL OUT_CHAR

                                MOV R7, #5
                                ACALL LOCATE2
                                MOV A, DSP3
                                ACALL DATA_OUT

                                MOV R7, #6
                                ACALL LOCATE2
                                MOV A, DSP2
                                ACALL DATA_OUT

                                MOV R7, #7
                                ACALL LOCATE2
                                MOV A, DSP1
                                ACALL DATA_OUT

                                POP DPL
                                POP DPH
                                RET

PRT_TITLE1:                     PUSH DPH                                % mencetak Header 1 %
                                PUSH DPL
                                MOV R7, #0
                                ACALL LOCATE1
                                MOV DPTR, #HEADER1
                                ACALL OUT_CHAR
                                MOV R7, #0
                                ACALL LOCATE2
                                MOV DPTR, #HEADER2
                                ACALL OUT_CHAR
```

Listing programs

```
ACALL DELAY_5S  
ACALL CLEAR_DISPLAY
```

```
MOV R7,#0  
ACALL LOCATE1  
MOV DPTR,#HEADER3  
ACALL OUT_CHAR  
MOV R7,#0  
ACALL LOCATE2  
MOV DPTR,#HEADER4  
ACALL OUT_CHAR
```

```
ACALL DELAY_5S  
ACALL CLEAR_DISPLAY
```

```
POP DPL  
POP DPH  
RET
```

PRT_TITLE2:

```
PUSH DPH % mencetak header 2 %  
PUSH DPL
```

```
MOV R7,#0  
ACALL LOCATE1  
MOV DPTR,#HEADER5  
ACALL OUT_CHAR  
MOV R7,#0  
ACALL LOCATE2  
MOV DPTR,#HEADER6  
ACALL OUT_CHAR
```

```
ACALL DELAY_5S  
ACALL CLEAR_DISPLAY
```

```
MOV R7,#0  
ACALL LOCATE1  
MOV DPTR,#HEADER7  
ACALL OUT_CHAR  
MOV R7,#0  
ACALL LOCATE2  
MOV DPTR,#HEADER8  
ACALL OUT_CHAR
```

```
ACALL DELAY_5S  
ACALL CLEAR_DISPLAY
```

```
POP DPL  
POP DPH  
RET
```

Listing programs

```
INIT_LCD:          PUSH DPH          % inisialisasi LCD %
                  PUSH DPL
                  PUSH PSW
                  PUSH ACC
                  MOV R0,#0FFH
                  ACALL DELAY_LOOP
                  MOV A,#00111000B
                  ACALL CTRL_OUT
                  MOV R0,#50H
                  ACALL DELAY_LOOP
                  MOV A,#00111000B
                  ACALL CTRL_OUT
                  MOV R0,#50H
                  ACALL DELAY_LOOP
                  MOV A,#00111000B
                  ACALL CTRL_OUT
                  MOV A,#00111000B
                  ACALL CTRL_OUT
                  MOV A,#00001000B
                  ACALL CTRL_OUT
                  MOV A,#00000001B
                  ACALL CTRL_OUT
                  MOV A,#00000110B
                  ACALL CTRL_OUT
                  POP ACC
                  POP PSW
                  POP DPL
                  POP DPH
                  RET

DELAY_LOOP:       PUSH DPH
                  PUSH DPL
DEL_LOOP:         DEC R0
                  NOP
                  NOP
                  NOP
                  CJNE R0,#0H,DEL_LOOP
                  POP DPL
                  POP DPH
                  RET

CLEAR_DISPLAY:   PUSH DPH          % membersihkan layar %
                  PUSH DPL
                  MOV A,#00000001B
                  ACALL CTRL_OUT
                  MOV R0,#0FFH
                  ACALL DELAY_LOOP
                  POP DPL
                  POP DPH
                  RET

DELAY_5S:        PUSH DPH          % delay 5 detik %
                  PUSH DPL
                  PUSH ACC
                  PUSH PSW
```

Listing programs

```
DEL1:      MOV A, #0FFH
DEL2:      MOV B, #0FFH
           DJNZ B, $
           DJNZ ACC, DEL2
           DJNZ R5, DEL3
           POP PSW
           POP ACC
           POP DPL
           POP DPH
           RET

DELAY_2S:  PUSH DPH           % delay 2 detik %
           PUSH DPL
           PUSH ACC
           PUSH PSW
           MOV R5, #06H
DEL3:      MOV A, #0FFH
DEL4:      MOV B, #0FFH
           DJNZ B, $
           DJNZ ACC, DEL4
           DJNZ R5, DEL3
           POP PSW
           POP ACC
           POP DPL
           POP DPH
           RET

DELAY_1S:  PUSH DPH           % delay 1 detik %
           PUSH DPL
           PUSH ACC
           PUSH PSW
           MOV R5, #03H
DEL5:      MOV A, #0FFH
DEL6:      MOV B, #0FFH
           DJNZ B, $
           DJNZ ACC, DEL6
           DJNZ R5, DEL5
           POP PSW
           POP ACC
           POP DPL
           POP DPH
           RET

DELAY:     PUSH DPH
           PUSH DPL
           PUSH ACC
           PUSH PSW
           MOV R5, TIME_DELAY
DEL7:      MOV A, #0FFH
DEL8:      MOV B, #0FFH
           DJNZ B, $
           DJNZ ACC, DEL8
           DJNZ R5, DEL7
           POP PSW
           POP ACC
           POP DPL
```

Listing programs

```
POP DPH
RET

HEADER1      DB 'MICROCONTROLLER ' % Karakter yang akan
dicetak di LCD %
HEADER2      DB '      DRIVEN      '
HEADER3      DB ' DIGITAL IODIUM '
HEADER4      DB '      TESTER      '
HEADER5      DB '  DESIGNED BY:  '
HEADER6      DB '  ANGKA WIJAYA  '
HEADER7      DB '    FTE UNIKA    '
HEADER8      DB '  WIDYA MANDALA  '
OUTPUT       DB ' IODIUM CONTAIN '
OUTPUT2      DB '           ppm           '

END
```



LAMPIRAN C

TABEL INSTRUKSI LCD

2.4 Instruction Outline

Table 5 List of instructions

Instruction	Code											Function	Execution time
	RS	R/W	DB ₇	DB ₆	DB ₅	DB ₄	DB ₃	DB ₂	DB ₁	DB ₀			
(1) Display clear	0	0	0	0	0	0	0	0	0	0	1	Clears all display and returns cursor to home position (address 0)	1.64 ms
(2) Cursor Home	0	0	0	0	0	0	0	0	0	1	*	Returns cursor to home position. Shifted display returns to home position and DD RAM contents do not change.	1.64 ms
(3) Entry Mode Set	0	0	0	0	0	0	0	0	1	I/D	S	Sets direction of cursor movement and whether display will be shifted when data is written or read	40 μs
(4) Display ON/OFF control	0	0	0	0	0	0	1	D	C	B	*	Turns ON/OFF total display (D) and cursor (C), and makes cursor position column start blinking (B)	40 μs
(5) Cursor/Display Shift	0	0	0	0	0	1	S/C	R/L	*	*	*	Moves cursor and shifts display without changing DD RAM contents	40 μs
(6) Function Set	0	0	0	0	1	DL	1	*	*	*	*	Sets interface data length (DL)	40 μs
(7) CG RAM Address Set	0	0	0	1	A _{CG}						Sets CG RAM address to start transmitting or receiving CG RAM data	40 μs	
(8) DD RAM Address Set	0	0	1	A _{DD}						Sets DD RAM address to start transmitting or receiving DD RAM data	40 μs		
(9) BF/Address Read	0	1	BF	AC						Reads BF indicating module in internal operation and AC contents (used for both CG RAM and DD RAM)	0 μs		
(10) Data Write to CG RAM or DD RAM	1	0	Write Data						Writes data into DD RAM or CG RAM	40 μs			
(11) Data Read from CG RAM or DD RAM	1	1	Read Data						Reads data from DD RAM or CG RAM	40 μs			

* : Invalid bit

A_{CG} : CG RAM addressA_{DD} : DD RAM address

I/D = 1 : Increment

I/D = 0 : Decrement

S = 1 : Display shift

S = 0 : No display shift

D = 1 : Display ON

D = 0 : Display OFF

C = 1 : Cursor ON

C = 0 : Cursor OFF

B = 1 : Blink ON

B = 0 : Blink OFF

S/C = 1 : Display shift

S/C = 0 : Cursor movement

R/L = 1 : Right shift

R/L = 0 : Left shift

DL = 1 : 8 bits

DL = 0 : 4 bits

BF = 1 : Internal operation in progress

BF = 0 : Instruction can be accepted

Table 3 Correspondence between character codes and character patterns

Upper bit 4 bit Lower bit 4 bit	0000	0010	0011	0100	0101	0110	0111	1010	1011	1100	1101	1110	1111
xxxx0000	CG RAM (1)		0	a	P	˘	P		˘	˘	˘	˘	˘
xxxx0001	(2)	!	1	A	O	a	4	˘	˘	˘	˘	˘	˘
xxxx0010	(3)	"	2	B	R	b	r	˘	˘	˘	˘	˘	˘
xxxx0011	(4)	#	3	C	S	c	s	˘	˘	˘	˘	˘	˘
xxxx0100	(5)	*	4	D	T	d	t	˘	˘	˘	˘	˘	˘
xxxx0101	(6)	%	5	E	U	e	u	˘	˘	˘	˘	˘	˘
xxxx0110	(7)	&	6	F	U	f	u	˘	˘	˘	˘	˘	˘
xxxx0111	(8)	'	7	G	W	g	w	˘	˘	˘	˘	˘	˘
xxxx1000	(1)	(8	H	X	h	x	˘	˘	˘	˘	˘	˘
xxxx1001	(2))	9	I	Y	i	y	˘	˘	˘	˘	˘	˘
xxxx1010	(3)	*:	:	J	Z	j	z	˘	˘	˘	˘	˘	˘
xxxx1011	(4)	+;	;	K	L	k	l	˘	˘	˘	˘	˘	˘
xxxx1100	(5)	;	<	L	*	l	l	˘	˘	˘	˘	˘	˘
xxxx1101	(6)	---	=	M	I	m	i	˘	˘	˘	˘	˘	˘
xxxx1110	(7)	;	>	N	^	n	˘	˘	˘	˘	˘	˘	˘
xxxx1111	(8)	/	?	O	_	o	˘	˘	˘	˘	˘	˘	˘

FOTO ALAT

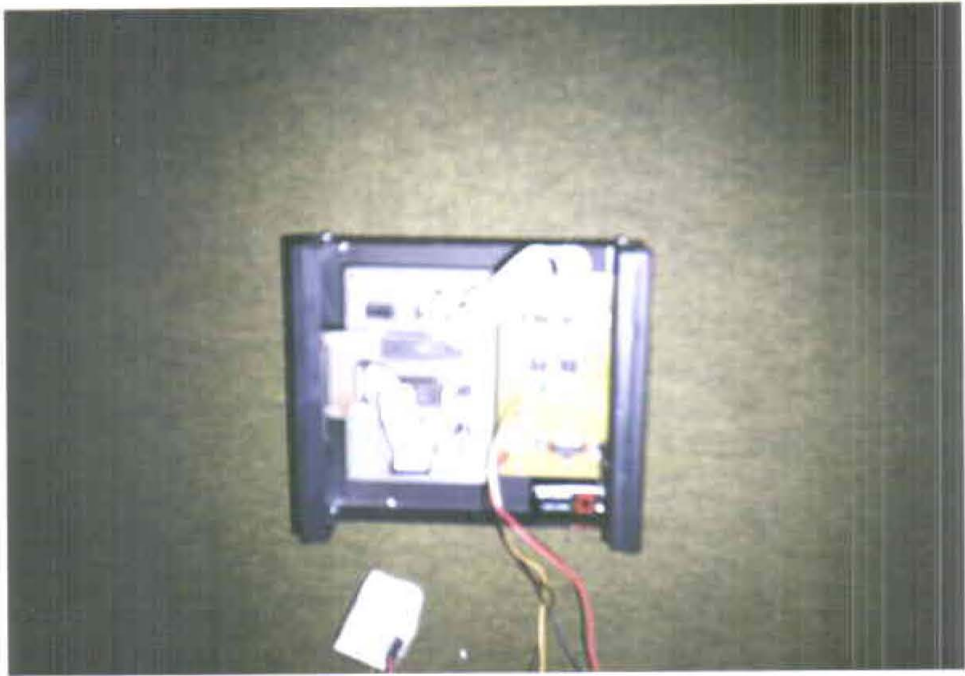

BIODATA



Nama : ANGKA WIJAYA ANGGARA
Nrp : 5103094038
Nirm : 94.7.003.31073.06042
Alamat : BABATAN PANTAI UTARA XV / 5
Tempat / Tgl Lahir : KOTABARU, 26 MEI 1974
Agama : KATOLIK
Hobby : OLAH RAGA (BASKET)

Riwayat Pendidikan :

Lulus SD Negeri Sebatung, Kotabaru, tahun 1988

Lulus SMP Negeri I, Kotabaru, tahun 1991

Lulus SMA Negeri I, Kotabaru, tahun 1994

Mahasiswa Universitas Katolik Widya Mandala Fakultas Teknik Jurusan Teknik Elektro, Surabaya, Angkatan 1994.