

**LAMPIRAN**

## Lampiran 1

### Kuisisioner untuk Pegawai

#### Pengaruh Motivasi Kerja, Kepemimpinan, dan Budaya Organisasi Terhadap Kepuasan Kerja Pegawai Serta Dampaknya Pada Kinerja Pegawai Negeri Sipil Di Direktorat Jenderal Perbendaharaan Departemen Keuangan Surabaya

#### Petunjuk pengisian:

1. Hasil dari daftar pertanyaan ini ditujukan untuk penelitian ilmiah, dalam penulisan tesis program S-2 Program Studi Management Strategik Universitas Katolik Widya Mandala Surabaya.
2. Daftar pertanyaan ini diisi oleh responden yang berkerja sebagai Pegawai Negeri Sipil di Direktorat Jenderal Perbendaharaan Departemen Keuangan Surabaya.
3. Bapak/Ibu/Saudara/I dimohon menjawab dengan cara memberikan tanda silang (X) pada kolom yang telah disediakan.
4. Parameter yang telah disediakan adalah sebagai berikut:

STS	=	Sangat Tidak Setuju
TS	=	Tidak Setuju
N	=	Netral
S	=	Setuju
SS	=	Sangat Setuju

**Karakteristik responden:**

1. Jenis kelamin:  Pria  Wanita
2. Usia:  22-30  31-40  41-50  > 50
3. Pendidikan terakhir (saat ini):  D1  D2  D3  
 S1  S2
4. Golongan:  1  2  3

**Daftar pertanyaan:**

No	Indikator	Jawaban				
		STS	TS	N	S	SS
<b>Motivasi Kerja (X<sub>1</sub>)</b>						
1.	Lingkungan kerja tidak menghalangi anda untuk berprestasi di bidang pekerjaan Anda (contoh: promosi jabatan).					
2.	Kesempatan untuk meningkatkan prestasi cukup luas.					
3.	Tersedianya kondisi kerja yang baik, terutama yang menyangkut keamanan pekerjaan.					
<b>Kepemimpinan (X<sub>2</sub>)</b>						
1.	Pimpinan selalu memberitahu dan memberikan arahan kepada Anda.					
2.	Pimpinan dan Anda ikut berperan serta dalam proses pengambilan keputusan.					
3.	Pimpinan mampu mendelegasikan wewenang, memberikan arahan, dan dukungan kepada Anda.					

No	Indikator	Jawaban				
		STS	TS	N	S	SS
<b>Budaya Organisasi (X<sub>3</sub>)</b>						
1.	Nilai-nilai organisasi yang ada telah dimengerti, dihayati dan diimplementasikan.					
2.	Terdapat integrasi antar unit-unit pekerjaan untuk bekerja secara terkoordinasi.					
3.	Adanya pemberian penghargaan atas pelaksanaan tugas dengan baik.					
<b>Kepuasan Kerja (Z<sub>1</sub>)</b>						
1.	Penghargaan yang adil dan layak diterima sesuai dengan jenis pekerjaan.					
2.	Suasana dan lingkungan pekerjaan Anda selalu nyaman.					
3.	Pimpinan bersikap bijaksana dalam menilai hasil pekerjaan Anda.					
4.	Pemberian promosi jabatan dan pengembangan karir atas hasil pekerjaan Anda.					

## Kuisisioner untuk Pimpinan

### **Pengaruh Motivasi Kerja, Kepemimpinan, dan Budaya Organisasi Terhadap Kepuasan Kerja Pegawai Serta Dampaknya Pada Kinerja Pegawai Negeri Sipil Di Direktorat Jenderal Perbendaharaan Departemen Keuangan Surabaya**

#### **Petunjuk pengisian:**

1. Hasil dari daftar pertanyaan ini ditujukan untuk penelitian ilmiah, dalam penulisan tesis program S-2 Program Studi Management Strategik Universitas Katolik Widya Mandala Surabaya.
2. Daftar pertanyaan ini diisi oleh responden yang berkerja sebagai Pegawai Negeri Sipil di Direktorat Jenderal Perbendaharaan Departemen Keuangan Surabaya.
3. Bapak/Ibu/Saudara/I dimohon menjawab dengan cara memberikan tanda silang (X) pada kolom yang telah disediakan.
4. Parameter yang telah disediakan adalah sebagai berikut:

STS	=	Sangat Tidak Setuju
TS	=	Tidak Setuju
N	=	Netral
S	=	Setuju
SS	=	Sangat Setuju

**Karakteristik responden:**

1. Jenis kelamin:  Pria       Wanita
2. Usia:  22-30     31-40     41-50     > 50
3. Pendidikan terakhir (saat ini):  D1     D2     D3  
 S1     S2
4. Golongan:  1       2       3

**Daftar pertanyaan:**

No	Indikator	Jawaban				
		STS	TS	N	S	SS
<b>Kinerja Pegawai (Y<sub>1</sub>)</b>						
1.	Pegawai mampu meningkatkan potensi dalam hal kualitas kerja dan pengetahuan mengenai pekerjaan dan ketrampilan.					
2.	Pegawai mampu untuk melaksanakan tugas-tugas baru dan beradaptasi dengan lingkungan yang baru.					
3.	Pegawai mampu menyelesaikan pekerjaan beserta persoalan-persoalan yang mungkin timbul sesuai dengan target yang telah ditetapkan.					

Lampiran 2

Jawaban Responden

1	4	4	4	4	4	4	4	4	4	4	4	4	4	4	4	2
2	5	5	5	4	5	5	5	5	4	4	4	4	5	5	5	4
3	4	4	4	4	4	4	4	4	4	4	4	4	4	4	4	4
4	4	4	4	3	4	4	4	4	4	4	4	4	4	4	4	4
5	5	5	5	4	5	5	5	5	4	5	5	5	5	5	4	3
6	4	4	4	3	4	5	4	4	4	4	3	4	5	4	3	4
7	4	4	4	3	4	5	4	4	4	5	4	5	5	5	5	5
8	5	5	5	5	5	5	5	5	5	5	5	4	5	5	5	5
9	5	5	5	5	5	5	5	4	4	4	5	5	5	5	5	5
10	5	5	5	5	5	5	5	5	5	5	5	5	5	5	5	5
11	5	5	5	5	5	5	5	5	5	5	5	5	5	5	5	5
12	5	5	5	5	5	5	5	5	5	4	4	5	4	4	4	4
13	4	4	4	4	4	4	2	3	4	4	4	4	4	4	4	4
14	5	5	4	4	4	5	4	2	2	5	4	3	3	4	3	1
15	4	4	4	4	4	4	4	4	4	4	4	4	4	4	4	4
16	2	3	3	4	3	4	3	4	3	2	3	4	4	4	3	3
17	4	4	4	4	4	4	4	4	4	4	4	4	4	4	4	2
18	4	4	4	4	4	5	4	4	4	5	4	4	4	4	4	4
19	4	4	4	4	4	4	4	4	4	4	4	4	4	4	3	4
20	4	4	4	5	5	5	4	4	4	4	4	4	4	4	4	4
21	5	5	5	5	5	5	5	5	5	5	5	5	5	5	5	5
22	4	4	4	3	4	4	4	5	4	4	3	4	5	4	4	4
23	5	4	4	4	4	5	4	4	3	4	4	4	3	4	5	4

24	5	5	3	4	5	5	3	3	4	3	4	5	5	4	2	2
25	4	4	4	4	4	4	4	4	4	4	4	4	5	4	4	3
26	5	5	4	4	5	5	5	4	4	4	4	4	4	5	4	4
27	4	4	4	4	4	4	4	4	4	4	4	4	4	4	4	4
28	4	3	3	4	4	4	3	3	3	2	3	2	2	4	4	3
29	4	4	4	4	4	5	5	4	3	4	4	5	5	5	3	3
30	5	5	5	4	5	5	4	4	4	4	4	4	4	4	4	4
31	5	5	4	4	4	5	4	4	4	4	4	4	4	4	4	3
32	4	4	4	4	4	4	3	4	4	4	4	4	4	3	3	5
33	5	5	4	4	5	5	5	5	4	4	4	4	4	4	4	4
34	5	5	5	4	5	5	5	5	4	4	4	5	5	5	5	4
35	5	5	5	5	5	5	4	5	4	4	4	4	5	4	4	4
36	4	4	4	4	5	4	4	4	4	4	5	4	5	4	5	5
37	5	5	5	4	5	5	5	5	4	4	4	5	5	5	5	4
38	5	5	4	4	5	5	4	4	4	4	4	4	5	4	4	4
39	5	5	4	5	5	5	4	5	4	4	5	4	3	4	4	4
40	4	4	4	4	4	4	4	4	4	4	4	4	4	4	4	4
41	5	5	4	4	4	4	4	4	3	4	4	3	5	3	3	4
42	4	4	4	4	4	5	4	4	4	4	4	4	4	4	4	3
43	5	5	5	4	5	5	5	5	5	4	4	5	4	5	5	5
44	4	4	4	4	4	5	4	4	4	4	4	3	3	4	4	4
45	4	4	4	4	4	5	4	4	4	5	4	4	4	4	4	4
46	4	4	4	4	4	4	2	4	4	4	4	4	4	4	4	4
47	5	4	4	4	3	4	4	4	4	4	4	3	4	4	5	3
48	5	5	5	5	5	5	4	5	4	4	4	4	4	5	4	5
49	4	4	4	4	4	4	4	4	4	4	4	4	4	4	4	4
50	5	5	4	4	4	4	4	4	4	4	4	5	4	4	4	4
51	5	4	5	4	5	5	5	4	4	4	4	4	4	4	5	4



52	4	4	4	4	4	5	4	4	4	4	4	4	4	4	4	3
53	5	4	5	4	5	4	1	3	2	5	4	1	4	5	4	1
54	4	4	4	4	4	4	2	3	4	2	3	4	4	4	4	4
55	5	5	3	4	4	5	3	4	4	5	4	4	4	4	4	3
56	5	4	5	4	5	5	4	4	4	4	4	5	5	4	4	4
57	3	3	4	4	3	4	4	4	4	5	4	3	3	4	4	4
58	4	4	3	5	4	4	5	4	4	4	4	4	5	4	4	5
59	5	5	5	4	5	5	5	5	4	4	4	4	4	5	4	2
60	5	5	5	4	5	5	5	5	4	4	4	4	4	5	4	2
61	5	5	5	4	5	5	5	5	4	1	1	4	5	5	4	4
62	5	4	4	4	4	5	3	4	4	4	4	4	4	4	4	3
63	4	4	4	4	4	4	3	4	4	4	4	4	3	4	5	4
64	5	5	5	3	4	5	5	3	5	4	4	4	3	3	4	4
65	4	4	4	4	5	5	5	4	4	5	5	4	5	5	4	3
66	4	4	4	4	5	5	5	5	4	4	4	4	5	4	4	3
67	4	4	3	4	4	5	4	4	5	5	5	4	4	4	4	4
68	4	4	4	4	5	5	5	5	4	5	4	4	4	4	4	3
69	4	4	4	5	5	4	4	4	4	5	4	4	4	4	4	5
70	5	5	5	5	5	5	5	5	5	4	4	4	4	5	5	5
71	5	5	5	4	4	4	3	4	4	4	4	5	4	4	4	3
72	5	5	5	4	5	5	5	5	5	4	4	4	4	5	5	4
73	5	5	5	4	4	5	4	4	4	4	4	4	4	4	4	4
74	4	4	4	4	5	5	5	5	4	4	4	4	4	4	4	3
75	5	4	5	5	5	5	4	4	5	4	4	5	5	4	4	5
76	5	4	5	5	5	5	4	4	5	4	5	5	5	4	4	4
77	5	5	4	4	4	5	4	4	4	4	4	4	3	4	5	4
78	4	4	4	4	4	5	5	4	5	5	4	4	5	4	5	3
79	5	5	5	5	5	5	4	5	4	5	5	4	4	5	5	4

80	5	5	5	4	4	5	5	4	3	4	4	4	3	4	3	4
81	5	5	5	4	4	5	4	4	4	4	5	3	5	4	4	4
82	4	4	4	4	5	5	4	4	5	5	5	4	5	3	3	3
83	5	5	4	5	4	5	5	4	4	5	4	4	5	4	4	4
84	4	4	4	4	4	5	5	5	4	5	5	4	5	5	4	4
85	4	4	5	5	4	5	5	5	4	4	4	4	4	4	4	3
86	5	5	5	4	4	5	5	5	5	4	4	5	3	4	4	3
87	4	4	4	4	4	4	2	4	4	4	4	4	4	3	4	2
88	4	4	4	3	4	4	4	4	4	4	4	4	4	4	4	4
89	5	5	5	4	4	5	4	4	4	5	5	3	5	4	4	4
90	5	5	5	4	4	5	4	4	4	4	5	3	5	4	4	4
91	4	4	4	3	3	4	3	3	3	4	4	4	4	4	3	2
92	4	4	4	4	4	4	4	4	4	4	3	4	4	4	4	3
93	4	4	5	5	4	5	5	5	5	4	4	4	4	5	5	4
94	4	4	4	4	4	5	4	4	5	4	4	4	4	5	5	4
95	5	5	5	4	5	5	4	4	4	5	5	5	5	5	5	4
96	4	4	4	4	4	5	4	4	5	4	4	4	4	5	5	4
97	4	4	5	5	4	5	5	5	5	4	4	4	4	4	4	4
98	4	2	2	4	2	4	4	4	4	4	2	2	4	5	5	5
99	4	4	4	4	4	5	4	4	5	4	4	4	4	5	5	4
100	4	4	4	4	4	5	4	4	5	4	4	4	4	5	5	4
101	4	4	4	4	5	5	5	5	4	3	3	4	4	4	5	4
102	5	4	4	4	4	5	4	4	4	4	4	3	4	3	4	3
103	4	4	4	4	4	4	2	3	4	5	4	4	4	4	3	2
104	5	5	4	4	4	5	5	4	4	5	5	4	4	4	2	2
105	5	5	4	5	5	5	5	4	4	4	4	4	4	5	5	5
106	4	4	4	3	5	4	4	4	4	4	3	3	4	4	4	5
107	4	4	4	4	4	5	4	4	3	3	4	3	4	4	3	4

108	4	4	4	2	4	4	4	4	4	2	2	4	4	4	4	4
109	4	4	4	4	4	4	4	4	4	4	4	4	4	4	4	2
110	5	5	4	4	5	5	4	4	4	4	4	3	5	4	4	4
111	5	4	4	3	5	5	3	4	4	4	3	3	5	4	5	4
112	3	4	4	4	4	4	3	3	4	4	4	3	4	4	4	4
113	4	4	4	4	5	4	4	4	4	4	4	4	4	4	4	4
114	4	4	4	4	4	5	4	4	5	5	5	4	4	5	5	4
115	5	5	5	4	4	5	4	5	4	5	4	4	4	4	5	3
116	4	4	4	4	4	5	5	4	5	4	4	3	4	5	5	4
117	4	5	4	4	5	5	4	3	4	4	4	3	3	4	4	1
118	4	4	4	4	4	4	4	4	4	5	5	4	4	4	4	2
119	4	4	5	4	4	5	5	4	4	4	4	4	4	4	4	3
120	4	5	4	4	4	5	5	4	4	4	4	4	4	4	4	3
121	4	4	4	4	4	4	4	4	4	4	4	4	5	4	4	3
122	4	4	4	4	4	5	3	4	4	4	4	4	4	4	4	3
123	5	4	4	4	4	5	2	4	4	4	4	4	5	5	5	2
124	4	4	4	3	4	5	4	4	4	4	4	4	4	4	4	1
125	4	4	4	4	5	4	4	4	4	5	5	4	4	5	4	4
126	5	5	4	5	5	5	5	5	5	5	5	5	5	4	4	4
127	5	4	4	5	4	5	5	4	4	5	4	4	5	4	4	5
128	5	5	5	5	5	5	4	4	4	5	5	4	5	5	5	4
129	4	4	4	4	4	4	3	4	4	5	4	4	4	4	4	4
130	5	5	5	5	5	5	4	5	5	5	3	5	5	5	5	5
131	4	4	4	4	4	5	5	3	3	5	4	5	4	5	4	3
132	5	5	5	5	5	5	4	4	5	5	4	4	4	4	4	4
133	5	5	4	4	4	5	2	5	4	5	4	4	4	4	5	2
134	4	3	4	3	3	3	3	3	3	3	4	4	3	3	3	3
135	5	4	4	4	3	4	2	4	4	4	4	4	4	4	4	3

136	4	4	3	3	4	4	2	4	3	4	4	4	4	4	4	2
137	4	4	4	4	3	5	4	3	4	4	4	3	4	4	3	4
138	4	4	4	4	4	4	4	4	4	4	4	4	4	4	3	4
139	4	4	4	2	3	4	4	3	4	4	4	4	3	4	3	4
140	4	4	4	4	4	4	4	4	4	4	4	4	4	4	4	3
141	5	4	4	4	5	5	4	4	4	5	5	5	5	4	5	4
142	5	5	4	3	4	5	2	4	3	4	3	1	5	5	2	2
143	4	4	4	4	4	5	4	4	4	4	4	3	3	4	4	4
144	5	5	4	4	5	5	4	4	3	4	4	3	4	4	4	3
145	4	4	5	4	4	4	4	5	4	4	4	4	4	4	5	4
146	5	5	4	4	5	5	4	4	3	4	4	3	4	4	4	3
147	2	1	1	2	1	3	3	2	2	3	3	3	3	4	4	2
148	2	4	5	5	2	2	5	4	3	3	3	3	3	4	4	2
149	3	4	3	4	3	4	4	2	4	4	3	4	3	3	3	4
150	2	4	2	2	3	4	2	2	2	4	4	3	4	3	4	3
151	2	4	1	4	2	3	3	2	4	3	2	2	1	4	4	3
152	4	4	4	4	2	4	4	5	5	3	3	3	2	4	4	5
153	5	4	4	4	5	4	5	5	4	2	2	3	3	4	4	5
154	4	3	2	4	5	4	5	5	4	4	4	4	4	3	2	5
155	4	4	4	3	3	3	3	2	3	2	1	4	2	4	4	4
156	4	4	4	4	4	4	4	4	4	3	3	3	3	4	5	5
157	4	3	4	2	2	3	3	3	3	1	3	2	2	4	4	5
158	3	3	3	4	4	4	3	4	4	3	3	2	1	3	2	5
159	4	4	4	4	4	4	4	4	4	3	2	2	3	4	3	5
160	4	4	4	4	4	4	4	4	4	2	3	2	3	4	4	5
161	3	4	3	3	3	3	3	3	3	3	2	3	1	3	3	5
162	4	4	4	2	3	2	3	3	3	3	3	3	3	4	4	5
163	4	4	4	3	3	3	3	3	3	1	3	3	2	3	4	5

7 2 2 2  
 2 2 2 2  
 2 2 2 2

164	3	4	3	3	3	3	4	3	4	4	4	4	5	3	3	5
165	3	3	3	3	3	3	3	3	3	2	2	2	1	4	4	4
166	5	4	5	4	4	4	4	4	4	3	2	2	2	5	4	5
167	3	3	3	3	3	3	3	3	4	2	2	3	1	4	4	5
168	5	4	5	3	3	3	3	3	3	4	3	3	4	5	5	4
169	4	4	4	3	3	3	3	3	3	3	3	3	3	4	4	4
170	3	4	3	5	4	4	3	3	4	3	3	2	3	4	4	4
171	3	3	3	4	4	4	4	5	5	4	4	4	3	3	3	4
172	4	4	4	4	4	5	4	5	5	2	2	2	2	4	3	4
173	4	3	4	5	5	5	5	4	4	2	1	2	2	5	5	5
174	3	3	4	5	4	4	4	4	4	1	2	2	2	3	4	5
175	5	5	5	5	5	5	5	5	5	3	4	4	5	4	4	5
176	5	5	5	4	4	4	4	4	4	2	1	2	2	5	5	5
177	5	5	5	5	5	5	5	5	5	5	5	5	5	5	5	5
178	5	5	5	4	4	4	5	5	5	3	2	4	2	5	5	5
179	5	5	5	5	5	5	5	5	5	5	5	5	5	5	5	5
180	5	5	5	5	5	5	5	5	5	5	5	5	5	5	5	5

**Lampiran 3**  
**Distribusi Frekuensi Karakteristik Responden**  
**Frequencies**

**Statistics**

		Jenis Kelamin	Umur	Pendidikan
N	Valid	180	180	180
	Missing	0	0	0
Mean		1.38	2.43	2.82
Std. Deviation		.488	.898	.799

**Frequency Table**

**Jenis Kelamin**

		Frequency	Percent	Valid Percent	Cumulative Percent
Valid	Laki-Laki	111	61.7	61.7	61.7
	Perempuan	69	38.3	38.3	100.0
	Total	180	100.0	100.0	

**Umur**

		Frequency	Percent	Valid Percent	Cumulative Percent
Valid	< 27 Tahun	29	16.1	16.1	16.1
	27 - <36 Tahun	65	36.1	36.1	52.2
	36 - <45 Tahun	65	36.1	36.1	88.3
	45 - < 54 Tahun	21	11.7	11.7	100.0
	Total	180	100.0	100.0	

**Pendidikan**

		Frequency	Percent	Valid Percent	Cumulative Percent
Valid	SMA	10	5.6	5.6	5.6
	Diploma	46	25.6	25.6	31.1
	S1	90	50.0	50.0	81.1
	S2	34	18.9	18.9	100.0
	Total	180	100.0	100.0	

**Lanjutan Lampiran 3**  
**Distribusi Frekuensi Jawaban Responden**  
**Deskriptif variabel Motivasi (X1)**

**Statistics**

		kebutuhan berprestasi	kebutuhan fisik	kebutuhan rasa aman
N	Valid	180	180	180
	Missing	0	0	0
Mean		4.31	4.24	4.14
Std. Deviation		.710	.648	.723

**Frequency Table**

**kebutuhan berprestasi**

		Frequency	Percent	Valid Percent	Cumulative Percent
Valid	Tidak Setuju	5	2.8	2.8	2.8
	Netral	11	6.1	6.1	8.9
	Setuju	88	48.9	48.9	57.8
	Sangat Setuju	76	42.2	42.2	100.0
	Total	180	100.0	100.0	

**kebutuhan fisik**

		Frequency	Percent	Valid Percent	Cumulative Percent
Valid	Sangat Tidak Setuju	1	.6	.6	.6
	Tidak Setuju	1	.6	.6	1.1
	Netral	12	6.7	6.7	7.8
	Setuju	105	58.3	58.3	66.1
	Sangat Setuju	61	33.9	33.9	100.0
	Total	180	100.0	100.0	

**kebutuhan rasa aman**

		Frequency	Percent	Valid Percent	Cumulative Percent
Valid	Sangat Tidak Setuju	2	1.1	1.1	1.1
	Tidak Setuju	3	1.7	1.7	2.8
	Netral	15	8.3	8.3	11.1
	Setuju	108	60.0	60.0	71.1
	Sangat Setuju	52	28.9	28.9	100.0
	Total	180	100.0	100.0	

**Kepemimpinan (X2)****Statistics**

		kemampuan untuk memberitahu anggota apa yang harus mereka kerjakan	kemampuan berpartisipasi dengan anggota	kemampuan mendelegasikan kepada anggota
N	Valid	180	180	180
	Missing	0	0	0
Mean		4.01	4.16	4.48
Std. Deviation		.664	.763	.672

**Frequency Table****kemampuan untuk memberitahu anggota apa yang harus mereka kerjakan**

		Frequency	Percent	Valid Percent	Cumulative Percent
Valid	Tidak Setuju	6	3.3	3.3	3.3
	Netral	21	11.7	11.7	15.0
	Setuju	119	66.1	66.1	81.1
	Sangat Setuju	34	18.9	18.9	100.0
	Total	180	100.0	100.0	

**kemampuan berpartisipasi dengan anggota**

		Frequency	Percent	Valid Percent	Cumulative Percent
Valid	Sangat Tidak Setuju	1	.6	.6	.6
	Tidak Setuju	5	2.8	2.8	3.3
	Netral	19	10.6	10.6	13.9
	Setuju	94	52.2	52.2	66.1
	Sangat Setuju	61	33.9	33.9	100.0
	Total	180	100.0	100.0	

**kemampuan mendelegasikan kepada anggota**

		Frequency	Percent	Valid Percent	Cumulative Percent
Valid	Tidak Setuju	2	1.1	1.1	1.1
	Netral	12	6.7	6.7	7.8
	Setuju	63	35.0	35.0	42.8
	Sangat Setuju	103	57.2	57.2	100.0
	Total	180	100.0	100.0	



### Budaya Organisasi (X3)

#### Statistics

		nilai - nilai organisasi	dukungan pimpinan	sistem imbalan
N	Valid	180	180	180
	Missing	0	0	0
Mean		4.00	4.05	4.02
Std. Deviation		.859	.719	.638

### Frequency Table

#### nilai - nilai organisasi

		Frequency	Percent	Valid Percent	Cumulative Percent
Valid	Sangat Tidak Setuju	1	.6	.6	.6
	Tidak Setuju	11	6.1	6.1	6.7
	Netral	27	15.0	15.0	21.7
	Setuju	89	49.4	49.4	71.1
	Sangat Setuju	52	28.9	28.9	100.0
	Total	180	100.0	100.0	

#### dukungan pimpinan

		Frequency	Percent	Valid Percent	Cumulative Percent
Valid	Tidak Setuju	6	3.3	3.3	3.3
	Netral	24	13.3	13.3	16.7
	Setuju	105	58.3	58.3	75.0
	Sangat Setuju	45	25.0	25.0	100.0
	Total	180	100.0	100.0	

#### sistem imbalan

		Frequency	Percent	Valid Percent	Cumulative Percent
Valid	Tidak Setuju	4	2.2	2.2	2.2
	Netral	23	12.8	12.8	15.0
	Setuju	119	66.1	66.1	81.1
	Sangat Setuju	34	18.9	18.9	100.0
	Total	180	100.0	100.0	

**Variabel Intervensi**  
**Kepuasan Kerja Pegawai (Z)**

**Statistics**

		kompensasi	kondisi kerja	kebijakan pimpinan	kesempatan untuk berkembang
N	Valid	180	180	180	180
	Missing	0	0	0	0
Mean		3.93	3.83	3.77	3.93
Std. Deviation		.891	.858	.824	.952

**Frequency Table**

**kompensasi**

		Frequency	Percent	Valid Percent	Cumulative Percent
Valid	Sangat Tidak Setuju	4	2.2	2.2	2.2
	Tidak Setuju	12	6.7	6.7	8.9
	Netral	18	10.0	10.0	18.9
	Setuju	105	58.3	58.3	77.2
	Sangat Setuju	41	22.8	22.8	100.0
	Total	180	100.0	100.0	

**kondisi kerja**

		Frequency	Percent	Valid Percent	Cumulative Percent
Valid	Sangat Tidak Setuju	4	2.2	2.2	2.2
	Tidak Setuju	12	6.7	6.7	8.9
	Netral	24	13.3	13.3	22.2
	Setuju	111	61.7	61.7	83.9
	Sangat Setuju	29	16.1	16.1	100.0
	Total	180	100.0	100.0	

**kebijakan pimpinan**

		Frequency	Percent	Valid Percent	Cumulative Percent
Valid	Sangat Tidak Setuju	2	1.1	1.1	1.1
	Tidak Setuju	14	7.8	7.8	8.9
	Netral	32	17.8	17.8	26.7
	Setuju	107	59.4	59.4	86.1
	Sangat Setuju	25	13.9	13.9	100.0
	Total	180	100.0	100.0	

## kesempatan untuk berkembang

		Frequency	Percent	Valid Percent	Cumulative Percent
Valid	Sangat Tidak Setuju	5	2.8	2.8	2.8
	Tidak Setuju	11	6.1	6.1	8.9
	Netral	25	13.9	13.9	22.8
	Setuju	90	50.0	50.0	72.8
	Sangat Setuju	49	27.2	27.2	100.0
	Total	180	100.0	100.0	

**Variabel Tak Bebas**  
**Kinerja Pegawai (Y)**

## Statistics

		Kemampuan pegawai dalam meningkatkan potensi yang dimiliki	Kemampuan pegawai dalam beradaptasi terhadap perubahan	Kemampuan Pegawai dalam mencapai target yang telah ditetapkan
N	Valid	180	180	180
	Missing	0	0	0
Mean		4.17	4.08	3.78
Std. Deviation		.568	.700	.978

## Frequency Table

## Kemampuan pegawai dalam meningkatkan potensi yang dimiliki

		Frequency	Percent	Valid Percent	Cumulative Percent
Valid	Netral	16	8.9	8.9	8.9
	Setuju	117	65.0	65.0	73.9
	Sangat Setuju	47	26.1	26.1	100.0
	Total	180	100.0	100.0	

## Kemampuan pegawai dalam beradaptasi terhadap perubahan

		Frequency	Percent	Valid Percent	Cumulative Percent
Valid	Tidak Setuju	5	2.8	2.8	2.8
	Netral	22	12.2	12.2	15.0
	Setuju	106	58.9	58.9	73.9
	Sangat Setuju	47	26.1	26.1	100.0
	Total	180	100.0	100.0	

**Kemampuan Pegawai dalam mencapai target yang telah ditetapkan**

		Frequency	Percent	Valid Percent	Cumulative Percent
Valid	Sangat Tidak Setuju	4	2.2	2.2	2.2
	Tidak Setuju	17	9.4	9.4	11.7
	Netral	35	19.4	19.4	31.1
	Setuju	83	46.1	46.1	77.2
	Sangat Setuju	41	22.8	22.8	100.0
	Total	180	100.0	100.0	

Lampiran 4 Amos

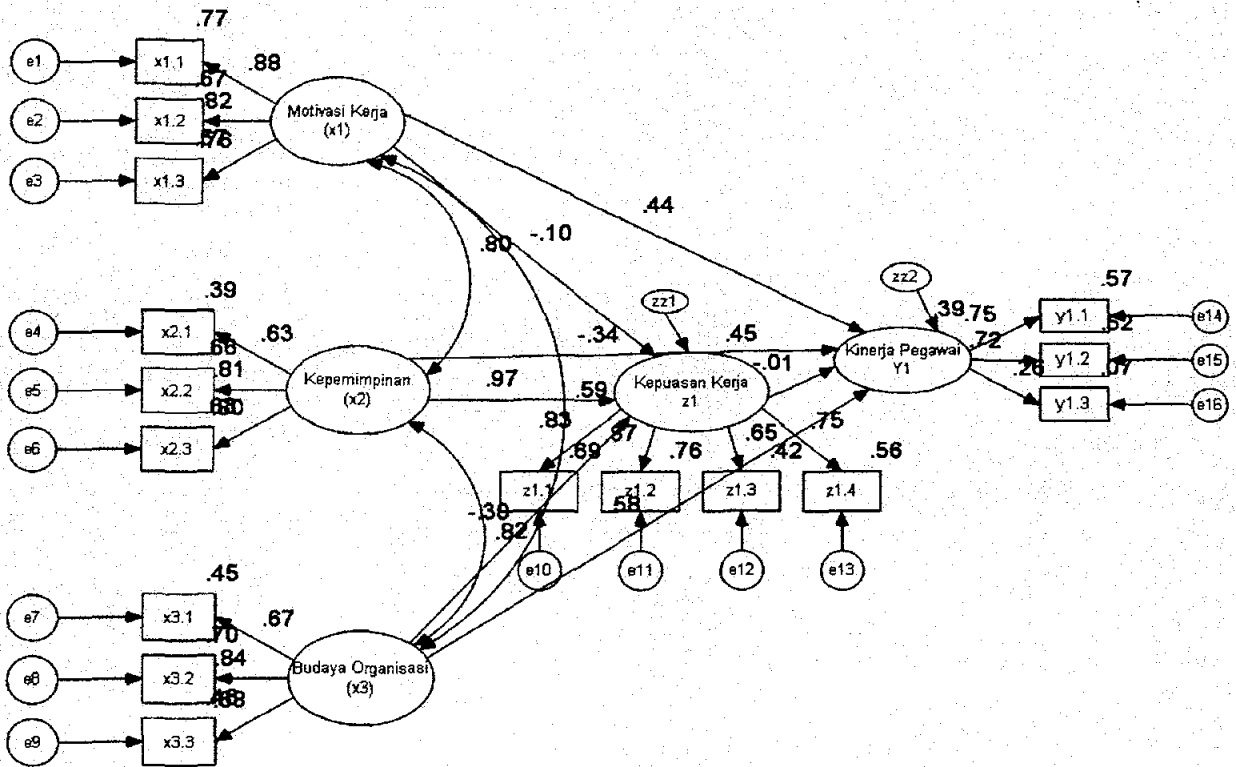

## Estimates (Group number 1 - Default model)

## Scalar Estimates (Group number 1 - Default model)

## Maximum Likelihood Estimates

## Regression Weights: (Group number 1 - Default model)

	Estimate	S.E.	C.R.	P	Label
Kepuasan Kerja_z1 <--- Motivasi Kerja_(x1)	-.125	.247	-.507	.612	par_12
Kepuasan Kerja_z1 <--- Kepemimpinan_(x2)	1.288	.462	2.787	.005	par_14
Kepuasan Kerja_z1 <--- Budaya Organisasi_(x3)	-.492	.380	-1.297	.195	par_15
Kinerja Pegawai_Y1 <--- Kepuasan Kerja_z1	-.005	.086	-.060	.952	par_13
Kinerja Pegawai_Y1 <--- Motivasi Kerja_(x1)	.347	.162	2.148	.032	par_16
Kinerja Pegawai_Y1 <--- Kepemimpinan_(x2)	-.270	.343	-.786	.432	par_17
Kinerja Pegawai_Y1 <--- Budaya Organisasi_(x3)	.578	.263	2.200	.028	par_18
x1.3 <--- Motivasi Kerja_(x1)	1.000				
x1.2 <--- Motivasi Kerja_(x1)	.970	.090	10.838	***	par_1
x1.1 <--- Motivasi Kerja_(x1)	1.135	.100	11.376	***	par_2
x2.3 <--- Kepemimpinan_(x2)	1.000				
x2.2 <--- Kepemimpinan_(x2)	1.158	.101	11.454	***	par_3
x2.1 <--- Kepemimpinan_(x2)	.777	.093	8.332	***	par_4
x3.3 <--- Budaya Organisasi_(x3)	1.000				
x3.2 <--- Budaya Organisasi_(x3)	1.391	.157	8.834	***	par_5
x3.1 <--- Budaya Organisasi_(x3)	1.331	.174	7.653	***	par_6
z1.4 <--- Kepuasan Kerja_z1	1.000				
z1.3 <--- Kepuasan Kerja_z1	.753	.088	8.567	***	par_7
z1.2 <--- Kepuasan Kerja_z1	1.053	.098	10.801	***	par_8
z1.1 <--- Kepuasan Kerja_z1	1.042	.099	10.515	***	par_9
y1.1 <--- Kinerja Pegawai_Y1	1.000				
y1.2 <--- Kinerja Pegawai_Y1	1.184	.196	6.038	***	par_10
Y1.3 <--- Kinerja Pegawai_Y1	.600	.231	2.597	.009	par_11

**Standardized Regression Weights: (Group number 1 - Default model)**

	Estimate
Kepuasan Kerja_z1 <--- Motivasi Kerja_(x1)	-.096
Kepuasan Kerja_z1 <--- Kepemimpinan_(x2)	.968
Kepuasan Kerja_z1 <--- Budaya Organisasi_(x3)	-.300
Kinerja Pegawai_Y1 <--- Kepuasan Kerja_z1	-.009
Kinerja Pegawai_Y1 <--- Motivasi Kerja_(x1)	.445
Kinerja Pegawai_Y1 <--- Kepemimpinan_(x2)	-.337
Kinerja Pegawai_Y1 <--- Budaya Organisasi_(x3)	.585
x1.3 <--- Motivasi Kerja_(x1)	.757
x1.2 <--- Motivasi Kerja_(x1)	.819
x1.1 <--- Motivasi Kerja_(x1)	.876
x2.3 <--- Kepemimpinan_(x2)	.795
x2.2 <--- Kepemimpinan_(x2)	.811
x2.1 <--- Kepemimpinan_(x2)	.625
x3.3 <--- Budaya Organisasi_(x3)	.678
x3.2 <--- Budaya Organisasi_(x3)	.837
x3.1 <--- Budaya Organisasi_(x3)	.671
z1.4 <--- Kepuasan Kerja_z1	.747
z1.3 <--- Kepuasan Kerja_z1	.650
z1.2 <--- Kepuasan Kerja_z1	.873
z1.1 <--- Kepuasan Kerja_z1	.832
y1.1 <--- Kinerja Pegawai_Y1	.754
y1.2 <--- Kinerja Pegawai_Y1	.724
y1.3 <--- Kinerja Pegawai_Y1	.662

**Covariances: (Group number 1 - Default model)**

	Estimate	S.E.	C.R.	P	Label
Motivasi Kerja_(x1) <--> Kepemimpinan_(x2)	.232	.036	6.402	***	par_19
Motivasi Kerja_(x1) <--> Budaya Organisasi_(x3)	.140	.028	5.006	***	par_20
Kepemimpinan_(x2) <--> Budaya Organisasi_(x3)	.189	.032	5.991	***	par_21

**Correlations: (Group number 1 - Default model)**

	Estimate
Motivasi Kerja_(x1) <--> Kepemimpinan_(x2)	.797
Motivasi Kerja_(x1) <--> Budaya Organisasi_(x3)	.593
Kepemimpinan_(x2) <--> Budaya Organisasi_(x3)	.821

**Variances: (Group number 1 - Default model)**

	Estimate	S.E.	C.R.	P	Label
Motivasi Kerja_(x1)	.298	.053	5.673	***	par_22
Kepemimpinan_(x2)	.284	.047	6.087	***	par_23
Budaya Organisasi_(x3)	.186	.039	4.745	***	par_24
zz1	.279	.062	4.506	***	par_25
zz2	.110	.031	3.558	***	par_26
e3	.221	.029	7.639	***	par_27
e2	.137	.020	6.804	***	par_28
e1	.117	.022	5.254	***	par_29
e6	.165	.023	7.166	***	par_30
e5	.198	.030	6.714	***	par_31
e4	.267	.031	8.609	***	par_32
e9	.219	.028	7.862	***	par_33
e8	.154	.031	5.032	***	par_34
e7	.404	.051	7.964	***	par_35
e13	.397	.053	7.540	***	par_36
e12	.390	.046	8.415	***	par_37
e11	.173	.033	5.293	***	par_38
e10	.243	.037	6.605	***	par_39
e14	.138	.031	4.433	***	par_40
e15	.232	.045	5.160	***	par_41
e16	.885	.097	9.082	***	par_42



**Squared Multiple Correlations: (Group number 1 - Default model)**

	Estimate
Kepuasan Kerja_z1	.445
Kinerja Pegawai_Y1	.395
y1.3	.069
y1.2	.523
y1.1	.568
z1.1	.692
z1.2	.763
z1.3	.422
z1.4	.559
x3.1	.450
x3.2	.701
x3.3	.459
x2.1	.391
x2.2	.658
x2.3	.632
x1.1	.767
x1.2	.671
x1.3	.574

**Matrices (Group number 1 - Default model)****Factor Score Weights (Group number 1 - Default model)****Total Effects (Group number 1 - Default model)**

	Budaya Organisasi_(x3)	Kepemimpinan_(x2)	Motivasi Kerja_(x1)	Kepuasan Kerja_z1	Kinerja Pegawai_Y1
Kepuasan Kerja_z1	-.492	1.288	-.125	.000	.000
Kinerja Pegawai_Y1	.581	-.276	.348	-.005	.000
y1.3	.348	-.166	.209	-.003	.600
y1.2	.688	-.327	.412	-.006	1.184
y1.1	.581	-.276	.348	-.005	1.000
z1.1	-.513	1.342	-.130	1.042	.000
z1.2	-.519	1.356	-.132	1.053	.000
z1.3	-.371	.970	-.094	.753	.000
z1.4	-.492	1.288	-.125	1.000	.000
x3.1	1.331	.000	.000	.000	.000
x3.2	1.391	.000	.000	.000	.000
x3.3	1.000	.000	.000	.000	.000
x2.1	.000	.777	.000	.000	.000
x2.2	.000	1.158	.000	.000	.000
x2.3	.000	1.000	.000	.000	.000
x1.1	.000	.000	1.135	.000	.000
x1.2	.000	.000	.970	.000	.000
x1.3	.000	.000	1.000	.000	.000

## Standardized Total Effects (Group number 1 - Default model)

	Budaya Organisasi_(x3)	Kepemimpinan_(x2)	Motivasi Kerja_(x1)	Kepuasan Kerja_z1	Kinerja Pegawai_Y1
Kepuasan Kerja_z1	-.300	.968	-.096	.000	.000
Kinerja Pegawai_Y1	.587	-.346	.446	-.009	.000
y1.3	.154	-.091	.117	-.002	.262
y1.2	.425	-.250	.322	-.006	.724
y1.1	.443	-.260	.336	-.006	.754
z1.1	-.249	.805	-.080	.832	.000
z1.2	-.262	.846	-.084	.873	.000
z1.3	-.195	.629	-.063	.650	.000
z1.4	-.224	.724	-.072	.747	.000
x3.1	.671	.000	.000	.000	.000
x3.2	.837	.000	.000	.000	.000
x3.3	.678	.000	.000	.000	.000
x2.1	.000	.625	.000	.000	.000
x2.2	.000	.811	.000	.000	.000
x2.3	.000	.795	.000	.000	.000
x1.1	.000	.000	.876	.000	.000
x1.2	.000	.000	.819	.000	.000
x1.3	.000	.000	.757	.000	.000

## Direct Effects (Group number 1 - Default model)

	Budaya Organisasi (x3)	Kepemimpinan_(x2)	Motivasi Kerja (x1)	Kepuasan Kerja_z1	Kinerja Pegawai_Y1
Kepuasan Kerja_z1	-.492	1.288	-.125	.000	.000
Kinerja Pegawai_Y1	.578	-.270	.347	-.005	.000
y1.3	.000	.000	.000	.000	.600
y1.2	.000	.000	.000	.000	1.184
y1.1	.000	.000	.000	.000	1.000
z1.1	.000	.000	.000	1.042	.000
z1.2	.000	.000	.000	1.053	.000
z1.3	.000	.000	.000	.753	.000
z1.4	.000	.000	.000	1.000	.000
x3.1	1.331	.000	.000	.000	.000
x3.2	1.391	.000	.000	.000	.000
x3.3	1.000	.000	.000	.000	.000
x2.1	.000	.777	.000	.000	.000
x2.2	.000	1.158	.000	.000	.000
x2.3	.000	1.000	.000	.000	.000
x1.1	.000	.000	1.135	.000	.000
x1.2	.000	.000	.970	.000	.000
x1.3	.000	.000	1.000	.000	.000

## Standardized Direct Effects (Group number 1 - Default model)

	Budaya Organisasi_(x3)	Kepemimpinan_(x2)	Motivasi Kerja_(x1)	Kepuasan Kerja_z1	Kinerja Pegawai_Y1
Kepuasan Kerja_z1	-.300	.968	-.096	.000	.000
Kinerja Pegawai_Y1	.585	-.337	.445	-.009	.000
y1.3	.000	.000	.000	.000	.262
y1.2	.000	.000	.000	.000	.724
y1.1	.000	.000	.000	.000	.754
z1.1	.000	.000	.000	.832	.000
z1.2	.000	.000	.000	.873	.000
z1.3	.000	.000	.000	.650	.000
z1.4	.000	.000	.000	.747	.000
x3.1	.671	.000	.000	.000	.000
x3.2	.837	.000	.000	.000	.000
x3.3	.678	.000	.000	.000	.000
x2.1	.000	.625	.000	.000	.000
x2.2	.000	.811	.000	.000	.000
x2.3	.000	.795	.000	.000	.000
x1.1	.000	.000	.876	.000	.000
x1.2	.000	.000	.819	.000	.000
x1.3	.000	.000	.757	.000	.000

## Indirect Effects (Group number 1 - Default model)

	Budaya Organisasi (x3)	Kepemimpinan_(x2)	Motivasi Kerja_(x1)	Kepuasan Kerja_z1	Kinerja Pegawai_Y1
Kepuasan Kerja_z1	.000	.000	.000	.000	.000
Kinerja Pegawai_Y1	.003	-.007	.001	.000	.000
y1.3	.348	-.166	.209	-.003	.000
y1.2	.688	-.327	.412	-.006	.000
y1.1	.581	-.276	.348	-.005	.000
z1.1	-.513	1.342	-.130	.000	.000
z1.2	-.519	1.356	-.132	.000	.000
z1.3	-.371	.970	-.094	.000	.000
z1.4	-.492	1.288	-.125	.000	.000
x3.1	.000	.000	.000	.000	.000
x3.2	.000	.000	.000	.000	.000
x3.3	.000	.000	.000	.000	.000
x2.1	.000	.000	.000	.000	.000
x2.2	.000	.000	.000	.000	.000
x2.3	.000	.000	.000	.000	.000
x1.1	.000	.000	.000	.000	.000
x1.2	.000	.000	.000	.000	.000
x1.3	.000	.000	.000	.000	.000

**Standardized Indirect Effects (Group number 1 - Default model)**

	Budaya Organisasi_(x3)	Kepemimpinan_(x2)	Motivasi Kerja_(x1)	Kepuasan Kerja_z1	Kinerja Pegawai_Y1
Kepuasan Kerja_z1	.000	.000	.000	.000	.000
Kinerja Pegawai_Y1	.003	-.008	.001	.000	.000
y1.3	.154	-.091	.117	-.002	.000
y1.2	.425	-.250	.322	-.006	.000
y1.1	.443	-.260	.336	-.006	.000
z1.1	-.249	.805	-.080	.000	.000
z1.2	-.262	.846	-.084	.000	.000
z1.3	-.195	.629	-.063	.000	.000
z1.4	-.224	.724	-.072	.000	.000
x3.1	.000	.000	.000	.000	.000
x3.2	.000	.000	.000	.000	.000
x3.3	.000	.000	.000	.000	.000
x2.1	.000	.000	.000	.000	.000
x2.2	.000	.000	.000	.000	.000
x2.3	.000	.000	.000	.000	.000
x1.1	.000	.000	.000	.000	.000
x1.2	.000	.000	.000	.000	.000
x1.3	.000	.000	.000	.000	.000

**Model Fit Summary****CMIN**

Model	NPAR	CMIN	DF	P	CMIN/DF
Default model	42	234.283	94	.000	2.492
Saturated model	136	.000	0		
Independence model	16	1515.829	120	.000	12.632

**RMR, GFI**

Model	RMR	GFI	AGFI	PGFI
Default model	.050	.857	.794	.593
Saturated model	.000	1.000		
Independence model	.207	.313	.221	.276

**Baseline Comparisons**

Model	NFI Delta1	RFI rho1	IFI Delta2	TLI rho2	CFI
Default model	.845	.803	.901	.872	.899
Saturated model	1.000		1.000		1.000
Independence model	.000	.000	.000	.000	.000

**Parsimony-Adjusted Measures**

Model	PRATIO	PNFI	PCFI
Default model	.783	.662	.705
Saturated model	.000	.000	.000
Independence model	1.000	.000	.000

**NCP**

Model	NCP	LO 90	HI 90
Default model	140.283	99.056	189.200
Saturated model	.000	.000	.000
Independence model	1395.829	1273.972	1525.095

**FMIN**

Model	FMIN	F0	LO 90	HI 90
Default model	1.309	.784	.553	1.057
Saturated model	.000	.000	.000	.000
Independence model	8.468	7.798	7.117	8.520

**RMSEA**

Model	RMSEA	LO 90	HI 90	PCLOSE
Default model	.091	.077	.106	.000
Independence model	.255	.244	.266	.000

**AIC**

Model	AIC	BCC	BIC	CAIC
Default model	318.283	327.097	452.387	494.387
Saturated model	272.000	300.543	706.242	842.242
Independence model	1547.829	1551.187	1598.916	1614.916



**ECVI**

Model	ECVI	LO 90	HI 90	MECVI
Default model	1.778	1.548	2.051	1.827
Saturated model	1.520	1.520	1.520	1.679
Independence model	8.647	7.966	9.369	8.666

**HOELTER**

Model	HOELTER .05	HOELTER .01
Default model	90	99
Independence model	18	19

**Assessment of normality (Group number 1)**

Variable	min	max	skew	c.r.	kurtosis	c.r.
y1.3	1.000	5.000	.731	1.004	.150	.412
y1.2	2.000	5.000	.605	1.311	.686	1.879
y1.1	3.000	5.000	.009	.048	-.164	-.450
z1.1	1.000	5.000	0.190	1.517	1.102	1.661
z1.2	1.000	5.000	0.155	1.326	1.133	1.746
z1.3	1.000	5.000	-.077	-1.805	.949	2.598
z1.4	1.000	5.000	1.065	1.835	1.130	3.094
x3.1	1.000	5.000	.796	1.361	.471	1.290
x3.2	2.000	5.000	.116	1.376	.610	1.671
x3.3	2.000	5.000	-.531	-1.907	1.044	1.133
x2.1	2.000	5.000	.694	1.801	1.079	1.775
x2.2	1.000	5.000	.959	1.253	1.027	1.181
x2.3	2.000	5.000	0.155	1.326	.981	2.687
x1.1	2.000	5.000	.984	1.389	1.241	3.399
x1.2	1.000	5.000	.923	1.132	1.888	1.910
x1.3	1.000	5.000	-0.193	-0.536	1.396	1.299
Multivariate					106.820	29.857

## Observations farthest from the centroid (Mahalanobis distance) (Group number 1)

Observation number	Mahalanobis d-squared	p1	p2
174	28.835	.025	.000
152	28.239	.030	.000
117	27.026	.041	.000
162	26.059	.053	.000
164	25.744	.058	.000
168	25.362	.064	.001
163	25.103	.068	.001
161	25.100	.068	.000
149	24.677	.076	.001
172	24.630	.077	.000
131	23.917	.091	.002
104	23.372	.104	.007
29	23.305	.106	.005
111	22.759	.120	.016
176	22.021	.143	.076
139	21.940	.145	.063
178	21.934	.145	.043
108	21.820	.149	.039
41	21.689	.154	.037
28	21.657	.155	.027
130	21.427	.163	.035
123	21.240	.169	.040
54	20.663	.192	.130
134	20.611	.194	.109
80	20.604	.194	.080
170	20.469	.200	.083
166	20.452	.201	.062
171	20.411	.202	.049
23	20.382	.203	.037
7	20.165	.213	.050
47	19.581	.240	.174
39	19.460	.246	.178
153	19.381	.249	.167
127	18.805	.279	.410
103	18.804	.279	.348
135	18.697	.285	.351
58	18.511	.295	.404
82	18.433	.299	.390
75	18.109	.318	.538
76	18.108	.318	.475
78	17.565	.350	.757
125	17.191	.373	.883
106	17.170	.375	.858

87	17.155	.376	.827
55	16.902	.392	.891
6	16.841	.396	.882
137	16.688	.406	.905
136	16.660	.408	.886
57	16.511	.418	.907
86	16.494	.419	.885
36	16.261	.435	.930
102	16.083	.447	.951
167	15.992	.454	.953
22	15.777	.469	.973
107	15.513	.487	.989
83	15.325	.501	.994
115	15.288	.504	.992
90	15.080	.519	.996
81	15.080	.519	.994
124	14.785	.540	.998
9	14.763	.542	.998
69	14.348	.573	1.000
101	14.326	.574	1.000
116	14.193	.584	1.000
51	14.004	.598	1.000
84	13.707	.620	1.000
112	13.688	.622	1.000
85	13.568	.631	1.000
159	13.514	.635	1.000
89	13.419	.642	1.000
165	12.894	.681	1.000
105	12.811	.687	1.000
65	12.771	.689	1.000
56	12.570	.704	1.000
48	12.566	.704	1.000
175	12.439	.713	1.000
60	12.427	.714	1.000
59	12.427	.714	1.000
141	12.279	.725	1.000
68	12.196	.730	1.000
77	12.172	.732	1.000
114	12.045	.741	1

**Sample Moments (Group number 1)**

**Sample Covariances (Group number 1)**

	y1.3	y1.2	y1.1	z1.1	z1.2	z1.3	z1.4	x3.1	x3.2	x3.3	x2.1	x2.2	x2.3	x1.1	x1.2	x1.3
y1.3	.951															
y1.2	.169	.487														
y1.1	.055	.219	.320													
z1.1	-.166	.100	.112	.789												
z1.2	-.144	.064	.052	.582	.731											
z1.3	.022	.125	.089	.356	.389	.676										
z1.4	-.077	.112	.151	.500	.504	.445	.900									
x3.1	.233	.133	.150	.144	.144	.267	.206	.733								
x3.2	.156	.157	.141	.154	.159	.222	.254	.344	.514							
x3.3	.226	.149	.086	.146	.136	.215	.146	.244	.260	.405						
x2.1	.123	.116	.105	.178	.179	.146	.173	.239	.239	.205	.439					
x2.2	.086	.120	.139	.234	.250	.253	.362	.267	.309	.186	.260	.580				
x2.3	-.043	.104	.139	.279	.261	.210	.324	.261	.243	.186	.208	.333	.450			
x1.1	.051	.141	.153	.200	.197	.186	.289	.167	.229	.117	.154	.323	.275	.501		
x1.2	-.001	.085	.113	.201	.203	.195	.240	.178	.177	.113	.154	.277	.226	.331	.418	
x1.3	.092	.183	.171	.138	.174	.198	.232	.239	.265	.159	.188	.278	.200	.335	.288	.520

Condition number = 40.082

Eigenvalues

3.698 1.510 .753 .551 .475 .424 .364 .317 .248 .223 .191 .170 .142 .135 .122 .092

Determinant of sample covariance matrix = 17.137

**Sample Correlations (Group number 1)**

	y1.3	y1.2	y1.1	z1.1	z1.2	z1.3	z1.4	x3.1	x3.2	x3.3	x2.1	x2.2	x2.3	x1.1	x1.2	x1.3
y1.3	1.000															
y1.2	.248	1.000														
y1.1	.100	.554	1.000													
z1.1	-.192	.162	.224	1.000												
z1.2	-.172	.108	.107	.766	1.000											
z1.3	.027	.217	.192	.487	.553	1.000										
z1.4	-.083	.168	.282	.594	.621	.570	1.000									
x3.1	.279	.223	.309	.190	.197	.379	.253	1.000								
x3.2	.223	.313	.348	.241	.259	.377	.373	.561	1.000							
x3.3	.364	.334	.239	.258	.250	.411	.241	.448	.570	1.000						
x2.1	.191	.251	.279	.303	.315	.268	.275	.421	.502	.487	1.000					
x2.2	.116	.226	.322	.346	.384	.405	.501	.409	.565	.384	.516	1.000				
x2.3	-.065	.222	.366	.469	.455	.381	.509	.455	.504	.437	.469	.653	1.000			
x1.1	.074	.286	.382	.318	.326	.320	.430	.275	.451	.260	.328	.599	.578	1.000		
x1.2	-.002	.189	.310	.350	.367	.366	.391	.321	.381	.274	.360	.563	.522	.723	1.000	
x1.3	.131	.363	.418	.215	.282	.335	.340	.387	.513	.346	.394	.506	.413	.657	.619	1.000

Condition number = 35.177

Eigenvalues

6.440 2.048 1.316 1.102 .789 .674 .568 .520 .483 .424 .384 .308 .289 .262 .207 .